



The Construction of the Timberless House Model

A step by step guide with photographs
and technical drawings

Practical Answers Sudan
The Practical Answers to Poverty Service



Acknowledgements

Extended thanks are given to the course participants from Abu Showk camp, for their excellent attitude during the training and workshops. With regards to this manual thanks are also given to the building consultants Yousef Hasan Adam and Ali Alzubair. Yousef wrote the original manual in Arabic and Ali Alzubair drew the technical drawings found at the back of the manual.

Contents

1. Introduction	p 4
2. Using mud as an alternative building material	p 8
3. Material and Equipment List	p 10
4. Building Instructions	p 13
5. Conclusion	p 23
6. Technical Drawings	p 24
7. Contact Information	p 33

The Construction of the Timberless House Model

1. Introduction

1.1. Darfur: The Housing Problem and a Solution

The conflict in Darfur, which most analysts judge to have started in 2003 has had a devastating effect on the region. Many of the internally displaced people (IDPs) who were forced to flee their homes have ended up living in make-shift camps around the major cities such as Alfashir, Algeneina and Nyala.

Upon their return back to their original villages, returnees are going to face numerous difficulties, the most significant of which will be the mass destruction of local infrastructure and homes.

1.2. Survey

In 2006 Practical Action Sudan decided to conduct a survey in Abu Showk IDP camp in Al Fashir to identify building designs and types of materials used by the IDPs in their home villages. The survey revealed the following:

- The IDPs in the camp have come from different areas (namely Korma, Tawilla, Kutum and Kabkabia) and belong to different ethnic groups in North Darfur.

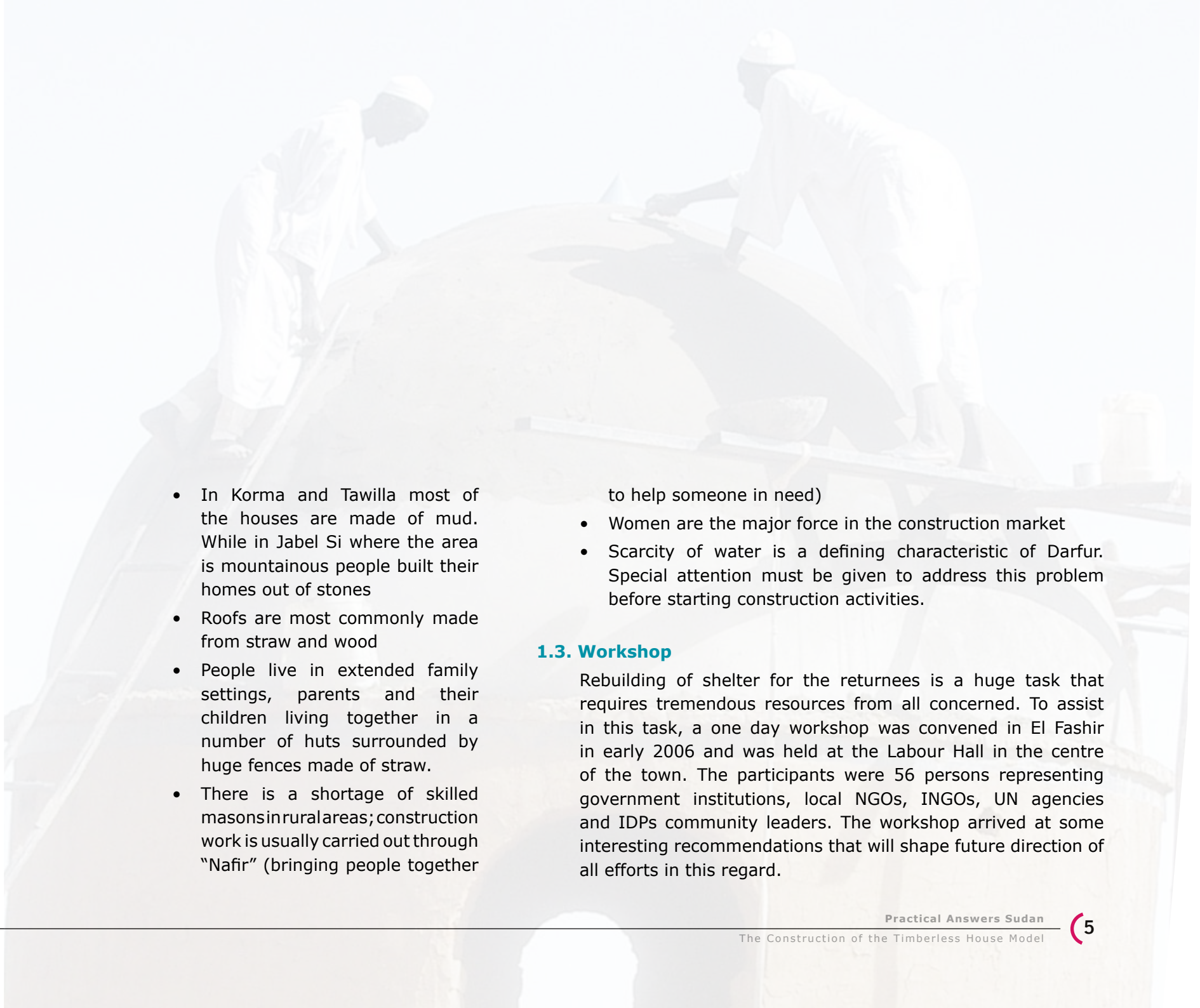
- 
- In Korma and Tawilla most of the houses are made of mud. While in Jabel Si where the area is mountainous people built their homes out of stones
 - Roofs are most commonly made from straw and wood
 - People live in extended family settings, parents and their children living together in a number of huts surrounded by huge fences made of straw.
 - There is a shortage of skilled masons in rural areas; construction work is usually carried out through “Nafir” (bringing people together

to help someone in need)

- Women are the major force in the construction market
- Scarcity of water is a defining characteristic of Darfur. Special attention must be given to address this problem before starting construction activities.

1.3. Workshop

Rebuilding of shelter for the returnees is a huge task that requires tremendous resources from all concerned. To assist in this task, a one day workshop was convened in El Fashir in early 2006 and was held at the Labour Hall in the centre of the town. The participants were 56 persons representing government institutions, local NGOs, INGOs, UN agencies and IDPs community leaders. The workshop arrived at some interesting recommendations that will shape future direction of all efforts in this regard.



1.4. Improved shelter training and model construction

The ability to build permanent houses for the returnees depends on the availability of materials and the existence of labour and skills. To this effect 70 trainees were selected and received training for 21 days on alternative shelter, building materials and building designs. The objective of the training was two fold: to introduce new building materials available locally for low cost housing to be used by the returnees in their areas and to have trained builders for the new intervention.

The curriculum for the training consisted of theoretical and practical parts with special emphasis on practical application to all steps of the construction process. The training finished with the completion of four demonstration housing units which were different in design and utilised different building materials. The training was convened at a piece of land at Um Shigaira which was provided by the Ministry of Housing and Physical Planning to a Womens Group who was to use the housing models as a training center once they were completed.

1.5. The Dome Roofed House as a Viable Alternative

Following the building of the four demonstration houses the consensus of opinion of those who took part was that the most appropriate design was the dome roofed house model (also referred to as the timberless house model as it is built without the use of wood). The traits and characteristics of the dome roofed house make it a suitable alternative to other forms of

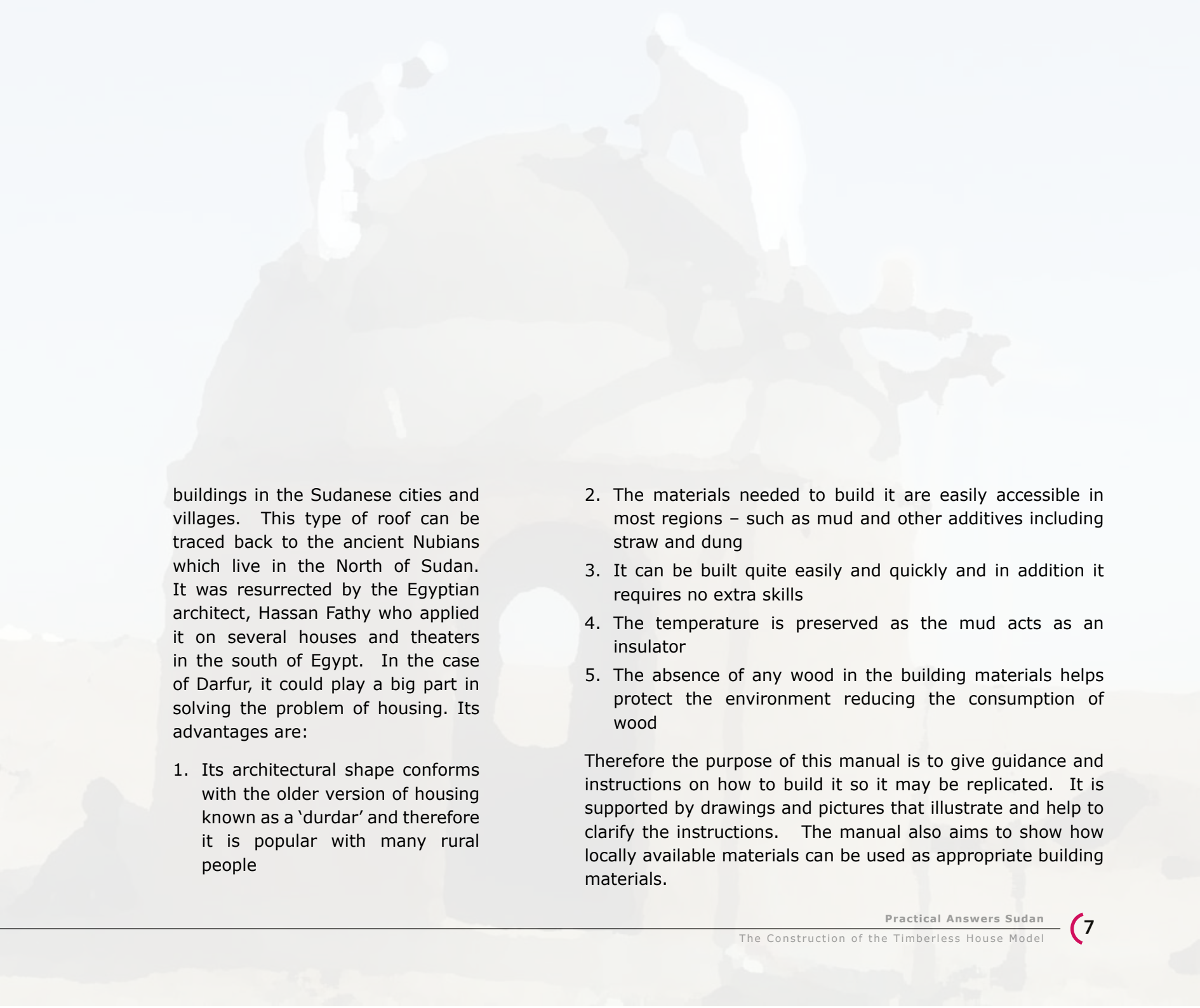

buildings in the Sudanese cities and villages. This type of roof can be traced back to the ancient Nubians which live in the North of Sudan. It was resurrected by the Egyptian architect, Hassan Fathy who applied it on several houses and theaters in the south of Egypt. In the case of Darfur, it could play a big part in solving the problem of housing. Its advantages are:

1. Its architectural shape conforms with the older version of housing known as a 'durdar' and therefore it is popular with many rural people

2. The materials needed to build it are easily accessible in most regions – such as mud and other additives including straw and dung
3. It can be built quite easily and quickly and in addition it requires no extra skills
4. The temperature is preserved as the mud acts as an insulator
5. The absence of any wood in the building materials helps protect the environment reducing the consumption of wood

Therefore the purpose of this manual is to give guidance and instructions on how to build it so it may be replicated. It is supported by drawings and pictures that illustrate and help to clarify the instructions. The manual also aims to show how locally available materials can be used as appropriate building materials.



Pic 1. *The mud should be mixed with water to form a sticky substance*

2. Using Mud as an alternative building material

Clay is readily available in Sudan, although its properties and colour differ from one region to the next. In the south and Nuba Mountains it is a red coloured substance that contains iron while in Dabal in central Sudan it is black.

One of the most important tasks for those wishing to use clay for building is to find out the quality of the clay in the area. There are a number of indigenous ways of doing this which do not require excessive amounts of measuring equipment, three of these are outlined below. However if you desire more accurate ways of determining the quality of clay, please contact the Practical Answers Team.

2.1. Shrink Test

- a) Choose a small amount of soil that is to be tested and mix it into a dough like mixture. Put the mixture on a plastic sheet and beat it to remove air and produce a good consistent mixture.
- b) Following this the mixture should be rolled between your hands until it is long and thin (see picture 1), measuring 10 cm in length and then left to dry for 24 hours. Using the rule it should be measured again to see how much the clay has shrunk. Ideally for good quality clay it should not have shrunk more than 10%



Pic 2. Wet clay rolled into a sausage shape 100 mm in length



Pic 3. In this example the clay had shrunk to 93 mm a shrinkage rate of 7% which is acceptable

of its length. Therefore, in this example it should still be at least 90 mm (see pictures 2 and 3).

2.2. Inspection using the senses

Firstly it is possible to get an indicator of the amount of clay contained in the soil by simply looking at the surface of the earth; if large cracks are found on the surface there is a good chance that there is clay present. You can also test the quality of the clay through touch. If the soil is clayey you will find it difficult to crumble it in your fingers. Furthermore, when you mix the clay with a little water if the soil is clayey it will stick to your hand and leave a stain.

2.3. Testing with a bottle:

- a) Prepare a clean and transparent bottle which one could see through. Partially fill the bottle with soil and add water. Shake the mixture well and put the bottle in a suitable place and leave to settle. After two hours lift the bottle and examine its contents.
- b) Normally the more coarse particles of sand will form in layers at the bottom with the soft mud layer on top. The amount of mud in the soil is determined according to its height. For good quality unburnt bricks the level of mud should at least exceed 60%.
- c) If the clay you test has in excess of 60% mud then it is suitable for use and should be mixed with animal dung or grass. If the mud content is less than 60% it should not be used.

3. Material and Equipment List

3.1 Material List (Omdurman Prices October, 2008)

No.	Descriptions	Unit	Price per Unit SDG	Amount	Total SDG
1	Mud to be beaten for green brick	m ³	10	20	200
2	Muna (clay and water) to tie up the brick	m ³	10	10	100
3	Sand (fine)	m ³	15	8	120
4	Donkey dung and straw mix	sack	6	10	60
5	Cement	sack	35	6 x 50 kg	210
6	Wire mesh (arnab)	3 meter roll	45	1	45
7	Sand (coarse)	m ³	15	6	90
8	Steel ring clamp for Dome Roof support	One piece	250	1	250
9	Asphalt for plastering	tin	35	3	105
10	Arch door 2 x 1 meters	1	300	1	300
11	Arch window 80 x 60 cm	1 frame	100	1	100
12	Chimney (Metal roof cover)	1	50	1	50
13	Lime (internal plastering)	1 sack	6	1	6
14	Gum Powder	kg	8	5	40
15	Water	barrel	3	50	150
				Total	1826

3.2 Material List (Al Fashir Prices October 2008, where available)

No.	Descriptions	Unit	Price per Unit SDG	Amount	Total SDG
1	Mud to be beaten for green brick	m ³	Free	20	0
2	Muna (clay and water) to stick the bricks together	m ³	Free	10	0
3	Sand (fine)	m ³	Free	8	0
4	Donkey dung and straw mix	sack	4	10	40
5	Cement	sack	45	6 x 50 kg	270
6	Wire mesh (arnab)	1 roll	45	1	45
7	Sand (coarse)	m ³	Free	6	0
8	Steel ring for Dome Roof support	One piece	250	1	250
9	Asphalt (Gum Arabic) for plastering	Big Tin	80	3	240
10	Arch door 2 x 1 meters	1	Recycled oil drum 150 SDG	1	100
11	Arch window 80 x 60 cm	1 frame	recycled oil drum 50 SDG	1	50
12	Chimney (Metal roof cover)	1	50	1	50
13	Lime (internal plastering)	1 sack	6	1	6
14	Gum Powder	kg	2.5	5	12
15	Water	barrel	6	50	300
				Total	1353

3.3 Equipment List

No.	Descriptions	Amount
1	Drill	2
2	Spade	2
3	Hoe / Toria	2
4	Rake / kuruk	1
5	Green Brick Mould 30 x 20 x 10	2
6	Green Brick Mould 22 x 11 x 7	2
7	Spirit Level	1
8	Plastering Tool (Mustareen)	2
9	Tape Measure	1
10	Building String	1 roll
11	Trowel Plasterboard	1
12	Axe / Bulta	1
13	Plasterboard / Tasheena (Cement smoothing tray)	1
14	Plasterboard / Taloosh	1
15	Chisel / Agina	2
16	Ladder	3
17	Sagala (Small wooden ladder)	1
18	Compass for measuring the dome	1
19	Metal pegs (40 cm)	5
20	Steel ring clamp (2 parts)	2
21	Ring clamp nut and Bolt (4" length and 1/4" thread)	4

3.4. The Cost of the house and community building "Nafir"

The table 3.2 above shows a table of costs for materials in Alfashir, North Darfur. As can be seen from this table the total costs are 1,353 SDG. To reach this low cost it is not necessary to have such high quality doors and windows as shown in this manual. It is possible to make suitable doors and windows from used items such as metal oil drums.

Also the aim is for these houses to be built through traditional community building techniques. This is where one family asks neighbours, family and friends to help them in building the house in return for food and drink. This will significantly reduce any perceived labour costs.

4. Building Instructions

4.1. Preparing the site

Before embarking on preparing the site the following procedures must take place:

Authority should be granted by the landowner or permits should be obtained if the land is government owned before work commences. Additionally a significant amount of water should be stored next to the work site and the site cleared from rubble, trees and grass; removing all debris with a brush.

4.2. Making the bricks.

The next step is the forming of the mud bricks; these mud bricks will form the walls and roof. To start, the type of mud must be chosen and should be light and contain no less than 30% sand. Water is added with additives such as straw or dung to reduce the lasticity of the clay as well as reducing its weight. The mixture needs to be stirred continuously which can take some time until the correct consistency is achieved. Suitable moulding casts should be prepared for the work. The technical drawing on page 32 shows the dimensions for a moulding cast for the large green brick, see diagram 1. A suitable size moulding cast can be made for the smaller

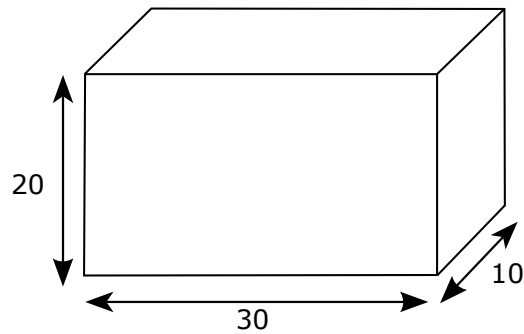

Diagram 1. Large Green Brick (Walls)
Dimensions in cm

green brick (diagram 4, p19) which is used for the roof. Once the mixture has been beaten the bricks can be formed in one of two ways:

Method 1. Removing water in the moulding cast: Slope Moulding

The metal or wooden moulding casts must be washed and cleaned in a bucket or container full of water. Next, the mud must be cut and shaped in the moulding cast, before the cast is removed. The mud should be one firm piece with no signs of cracks or unevenness. The mud should be pressed so that there are sharp well defined corners.



Pic 4. A participant using a moulding cast for brick production

Method 2. Removing water using sand: Sand Moulding

Once again the cast should be cleaned in water in a bucket or container. This time the mould is lined with sand to form an insulated layer so the mud can slide out easier when the mould is lifted. This gives the brick extra quality and more rigid edges. However the downside of this technique is that it is slower so invariably the builders prefer the first method.

Drying the bricks is the next stage and is considered a key part of the brick making process. The bricks should be left in the open air to dry for a total of three days until all the water dries out. It is better that the bricks are made at the same building site so that they do not crack while being moved.

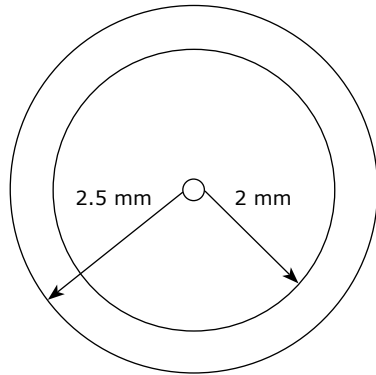

Diagram 2. Marking the foundations

4.3. Marking the Foundations

On a flat clean surface an appropriate point for the center of the building is chosen and an iron peg is put in the ground to mark it. A piece of rope or tape is tied at one end to this peg and at the other end to a peg that is used for marking. This device can now be used to mark the position of the foundations. The peg is used to mark a circle on the ground with a radius of 2 meters. A second circle is drawn with a radius of 2.5 meters. Once the lines have been drawn chalk or lime can be used to embolden them.

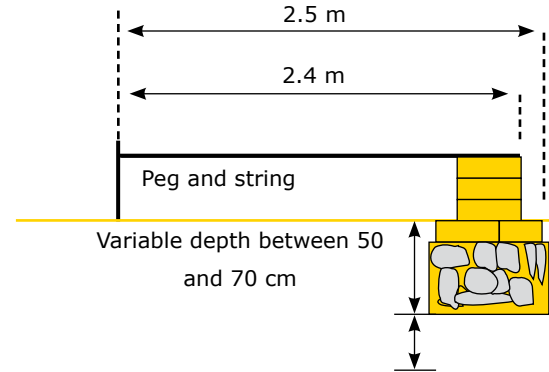

Diagram 3. Walls and Foundations

4.4. Building the Foundations

The 50 cm wide area for the foundations is dug to a depth of 50 – 70 cm. This small depth is enough due to the light weight of the building that will sit above these foundations. Accuracy is important when digging the foundations and a measuring device such as a tape measure should be constantly used to check the distance. The depth of the foundations will vary depending on the quality of the soil; if the soil is very sandy a depth of 70 cm is recommended.

Once the hole is dug, the bottom 40 cm (if the hole is 50 cm deep) is filled with bricks or a combination of rocks, gravel and sand. Large green bricks (30 x 20 x 10) are then laid one course below ground level, known as Al - Absha (see diagram 3), at this point the surface should be leveled. The second stage is to build the flood protection layer which is built 50 cm above the surface also using the 30 x 20 x 10 green bricks, they are bound with a small amount of muna (clay and water mix acting as cement). These courses will later be covered with asphalt.



Pic 5. The tape and peg are used for marking the radius of walls



Pic 6. The wall reaches three courses in height



Pic 7. The wall is built up leaving a gap for the door

4.5. Building the walls

Before starting the space of the door should be marked out. The width of the door should be 102 cm (2 cm for plastering).

The best way of doing this is to use a piece of string 2.5 meters in length and a spirit level. The string is tied to a peg which is located at the center of the circle. As the walls get higher the center peg is replaced by a pole. Bricks are laid one row at a time with a layer of muna (mud used to bond the bricks) in between to bond them together (see pictures 5 - 7). The spirit level is used to make sure that the layers are level.

After 5 courses the gap for the door should be left open (see pic 7).

The building of the wall then continues until a height of 1 meter at which point a gap of 62 cm is made for the window. The door and one window are located at 180°. It is possible to have another window although this should be kept small so as not to weaken the structure.

4.6. Building the arches for the door and windows

It is preferable with this type of building to use arches instead of rectangular shapes for the doors and windows. One of two methods can be used:

Method a) Using ready made metal girders is convenient for the goals of this house as it prevents the use of wood which is becoming scarce and is prone to rot. The metal girder is placed on bricks within the window frame these bricks will be removed with the girder once the arch is set.



Pic 8. Building the window arch using a metal girder



Pic 9. The door arch using method 2; a girder made from bricks and muna



Pic 10. The window arch using method 2

Burnt bricks are then placed along the surface of the girder once again using muna to bond them. The triangular gaps between them should be filled with gravel and bits of broken brick. The arches are left to set for 24 hours at which time the girder and supporting bricks can be removed.

Method b). The second and cheaper way is to use a girder made out of brick and muna, which is known as the tanfeekha (see pics 9 and 10).

Once the arches are complete two more courses of large green bricks are placed above the arch. After these, two courses of red bricks are added, this is known as the Madamek stage. The red bricks used for the arches and the madamek courses will need to be bought and should be similar in size to the small green bricks used for the dome, 22 x 11 x 7 cm.



Pic 11. Two courses of red bricks are laid on top of the green bricks

4.7. Using the steel ring clamp

The steel ring clamp is very important in the construction of the



Pic 12. Using the steel clamp to support the walls



Pic 13. Plastering the base of the house



Pic 14. Bricks are laid for the formation of the dome

domed roof building because it can tolerate great pressures made on it by the roof and the walls. Its main purpose is to resist these pressures preventing collapse. It is made in two halves and it is bolted together in two places 180° apart (see pictures 11 and 12). The steel ring clamp is placed around the madamek layers and bolted in place.

4.8. The side supporting walls

The use of side supporting walls is optional. During the building of the model house they were not used. Their main purpose is to support and strengthen the walls. They must be thick enough to support the roof and the pressures resulting from it (see the technical drawing 9, p31).

4.9. Plastering the base

The bottom five courses of the house are plastered with a cement mix for flood protection and also to stop the damp coming up through the soil.



Pic 15. The dome measuring tool is used to form the dome.



Pic 16. The wire mesh is tied around the partly made dome



Pic 17. Cement is plastered on top of the wire mesh

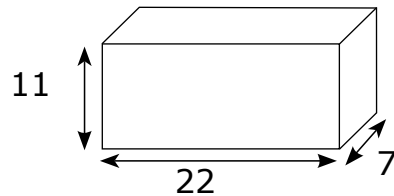
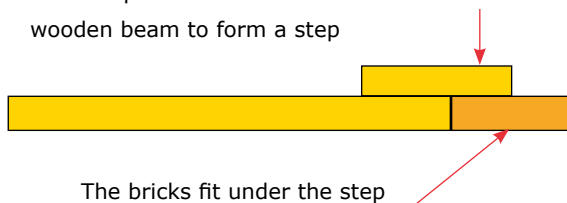

Diagram 4. Small Green Brick (Roof) Dimensions in cm

Another piece of wood is nailed to the wooden beam to form a step



The bricks fit under the step

Diagram 5. The end of the measuring tool

4.10. The Nubian Domed Roof

The type of brick used in the construction of the dome has to be light in weight and have the dimensions shown in diagram 4. The brick mould shown in tech drawing BM-01, p32 can be re-made so it makes a brick 22cm x 11cm x 7cm.

The first course of bricks is laid at a slight angle inwards and is positioned up against the ring clamp. After a course of bricks had been laid a layer of muna is spread over them. This muna should have some straw or refuse mixed with it.

A measuring tool is used (see diagram 5 and pic 15) to accurately place the bricks so that every course is angled more and more inwards thus forming the dome (see pictures 16 – 21). The end of this measuring device which cannot be seen in the photo looks like this:

After the courses reach a height of 1/2 meter the building of the roof stops as wire mesh needs to be wrapped around the



Pic 18. A course of red bricks act as a gutter



Pic 19. Further courses are added to form the dome



Pic 20. The dome roof from inside, a small hole is left in the top for ventilation



Pic 21. The metal hole cover can just be seen at the top of the house

existing roof courses, thus strengthening the dome. The role of wire mesh normally comes in a 1m wide role and it should be folded over once (so it is 1/2 meter in width) and wrapped around the roof three times. As can be seen in pictures 16 – 18 some scaffolding is set up so the roof can be worked on. For this purpose temporary holes are made in the walls and roof. One of these holes can be seen in picture 19. These holes should be filled in once the scaffolding is removed.

Once the wire mesh is securely in place then cement is used to cover it, this is known as 'libsha'.

A row of red bricks is placed along the edge and acts as a gutter to draw water away from the walls and foundations.

The dome walls are extended until a small opening 30 cm in diameter is left at the top for hot air to escape through. A small metal cover is fixed over this hole to prevent birds and insects from entering (see pic 21).



Pic 22. *Plastering the roof.*



Pic 23. *Plastering the outer walls*



Pic 24. *A lady plasters the inside walls*

4.11. Plastering the roof

This is a very important stage and can be achieved through a variety of materials. For example sand can be used with asphalt and should be mixed together at a ratio of 1:2 (asphalt / sand). In this case the asphalt should be heated first and dried with gasoline or kerosene before being mixed with soft sand. It should be applied to the roof in a layer 2cm thick which will protect the roof from rain and humidity.

4.12. Plastering the walls on the outside

The plaster for the outside walls is made using sand that is mixed with

local materials such as coloured mud mixed with sand or lime. Local skills and expertise may need to be used at this stage. This can also be done at an earlier stage as shown in picture 23.

4.13. Plastering the inside walls

Plastering the walls on the inside is made using sand that is mixed with gum arabic powder. Like the outside walls other local materials can be used such as coloured mud mixed with sand or lime (see picture 24).

4.14. The Floor

The floor in most rural homes uses a thin layer of sand and that is the most appropriate method for this building. If this house was to be built in an urban area the ground could use braided brick, stone, concrete or tiles.



Pic 25. Four holes are made around the sides of the window hole



Pic 26. The window frame is inserted



Pic 27. Cement is used to fix the window frame in place

4.15. Assembling the Doors and Windows

The standard door and window frames need to have wall support brackets welded to them that can be embedded in the wall. Using a chisel, small parts of the wall are removed where the door and window brackets will be inserted, see pic 25 -27. The door frame is fixed in the same way also with four bracket holes, two on each side.

Note: Pics 25 to 27 have been taken from a different building design but the window fitting is the same



Pic 28. A completed dome roof house model

5. Conclusion

For a family the mud dome building applications could include several units equal in size and height adapted for different purposes. For example if one was to be a kitchen it would be important for the opening in the roof to be larger in size to allow for better ventilation. It can also easily be converted to a toilet.

This type of building is considered an appropriate solution to the housing problem in both rural and suburban areas in many Sudanese provinces. It could be promoted at many indigenous and foreign organisations and architectural institutes and ministries of Planning and Architecture in the provinces. If you have any questions regarding this work please contact one of the members of the Practical Answers team who will be happy to answer your enquiry.

Technical Drawings

① Marking the External Diameter

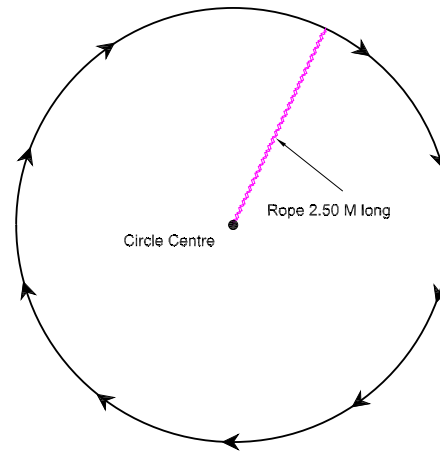

② Marking the Internal Diameter

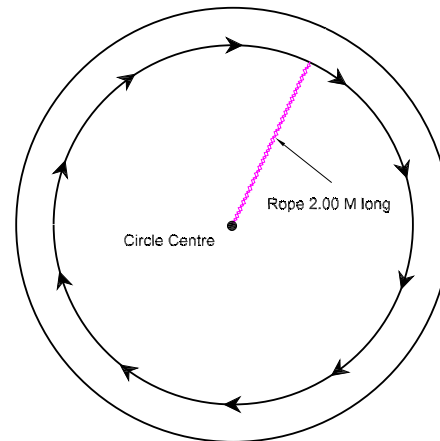

③ Foundation Excavation

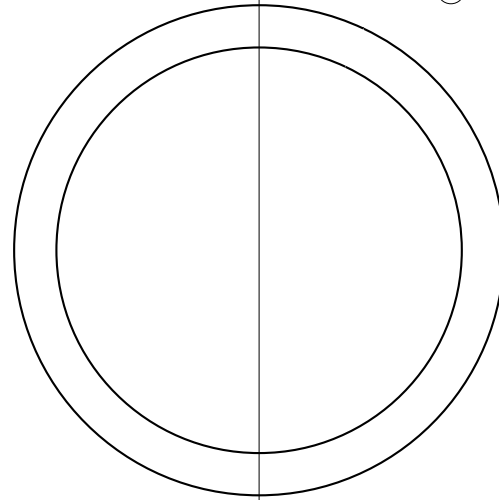

P L A N

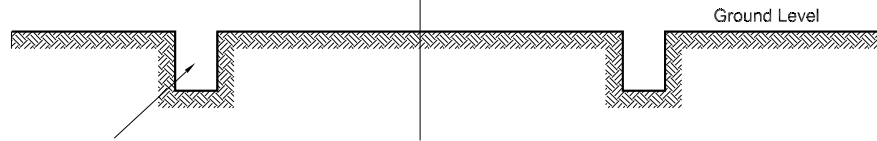

Foundation Depth from 50 cmm to 70 cmm depending on soil type

S E C T I O N

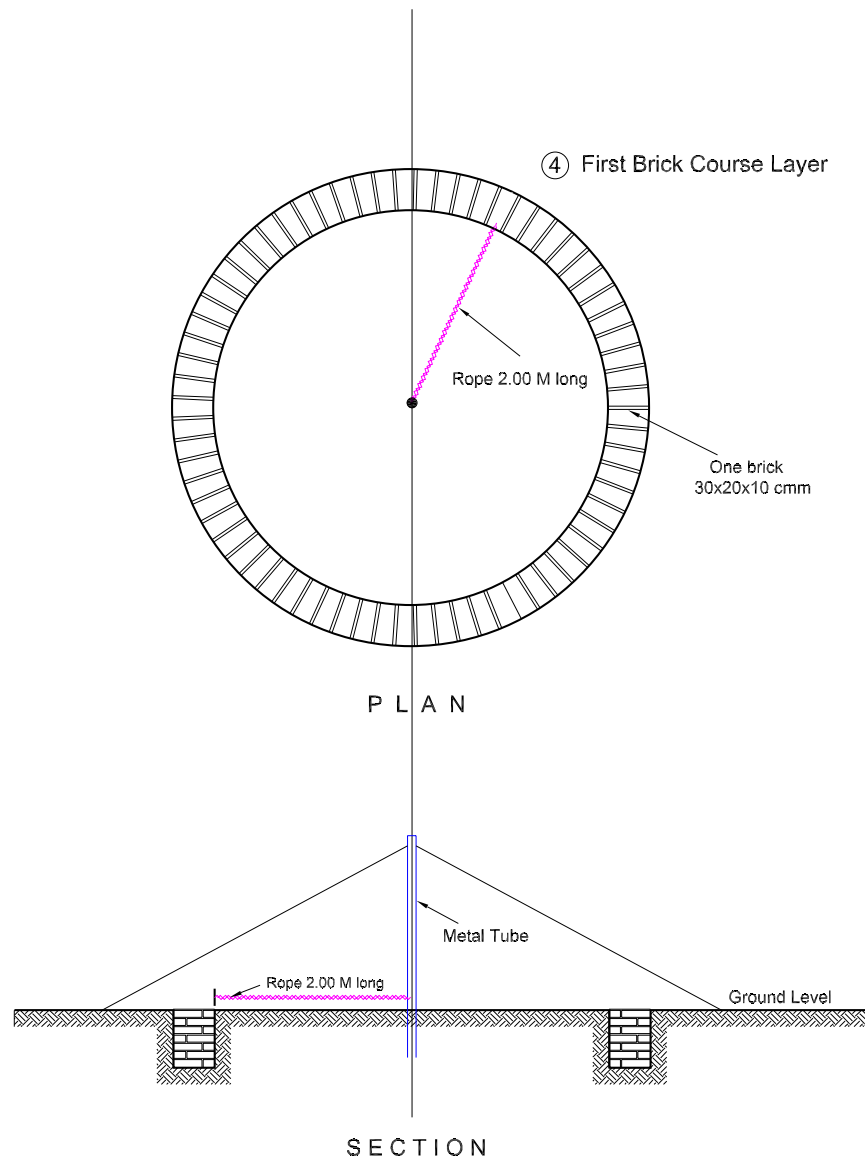

⑤ External Walls

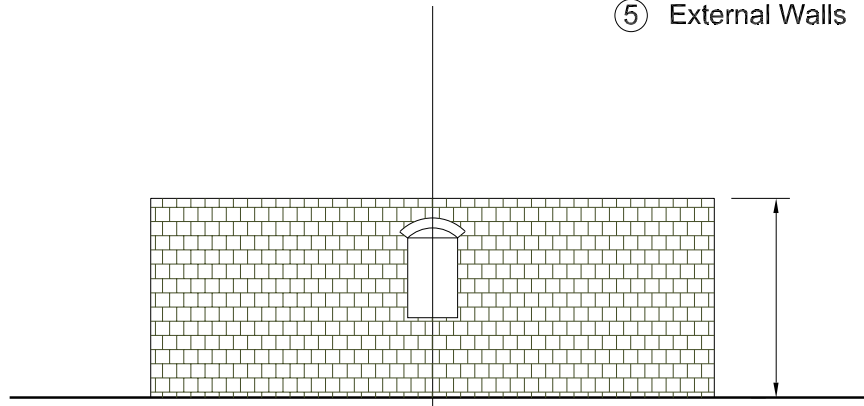

ELEVATION

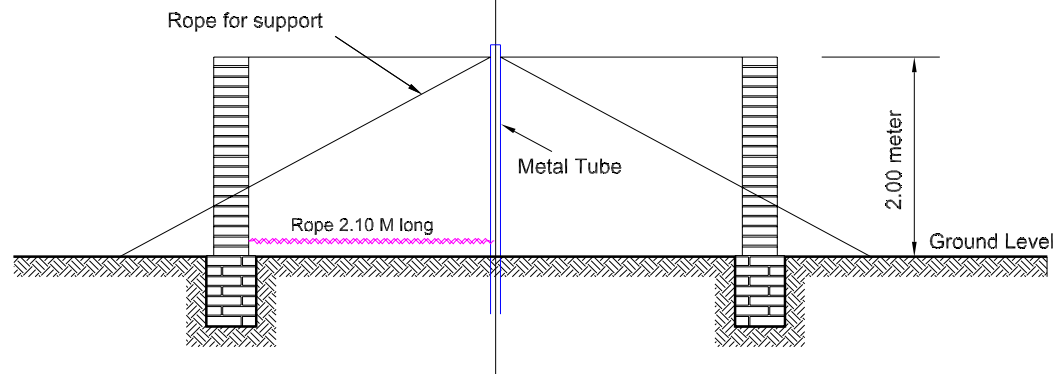

SECTION

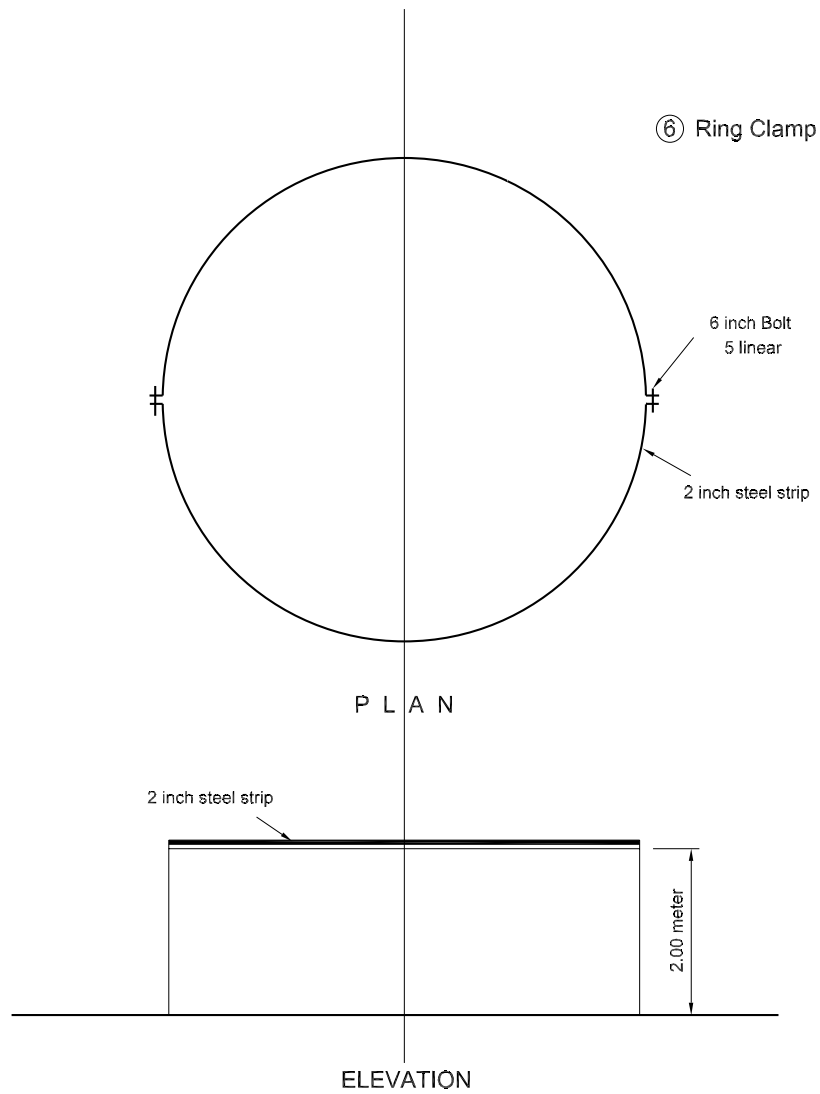

⑦ The Dome Roof

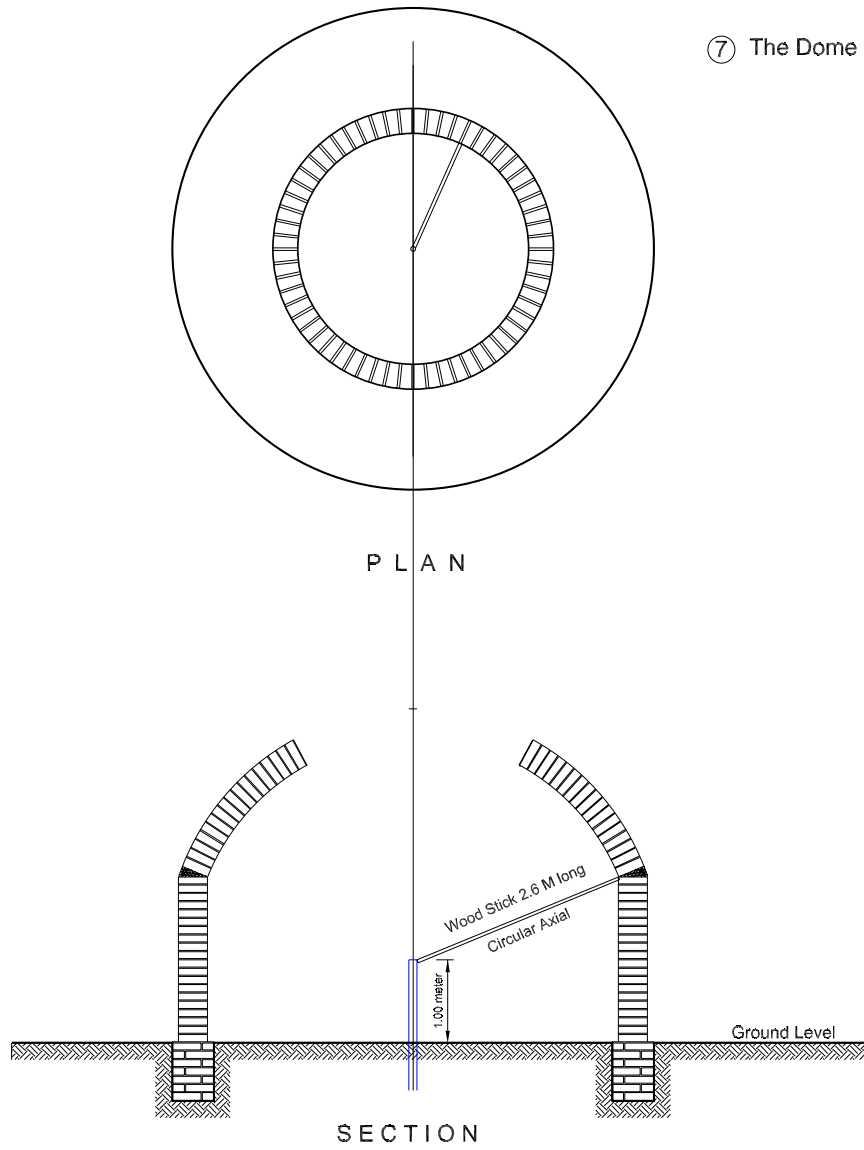

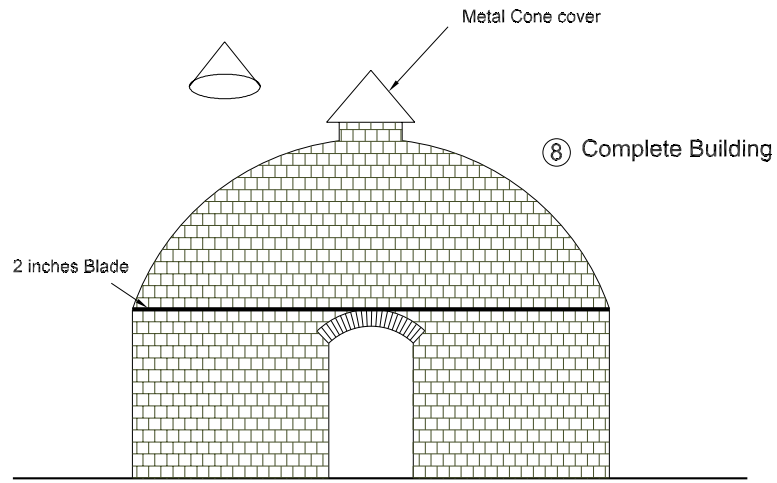

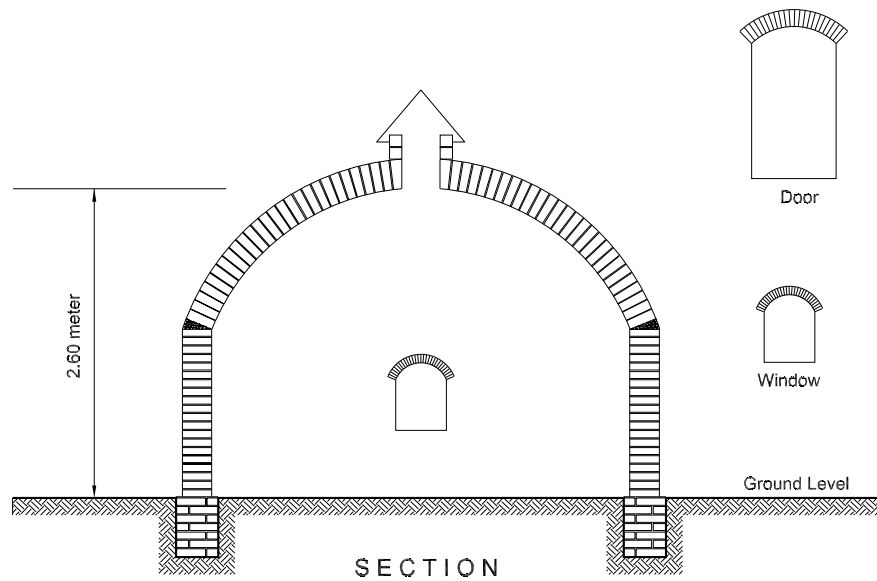

FRONT ELEVATION

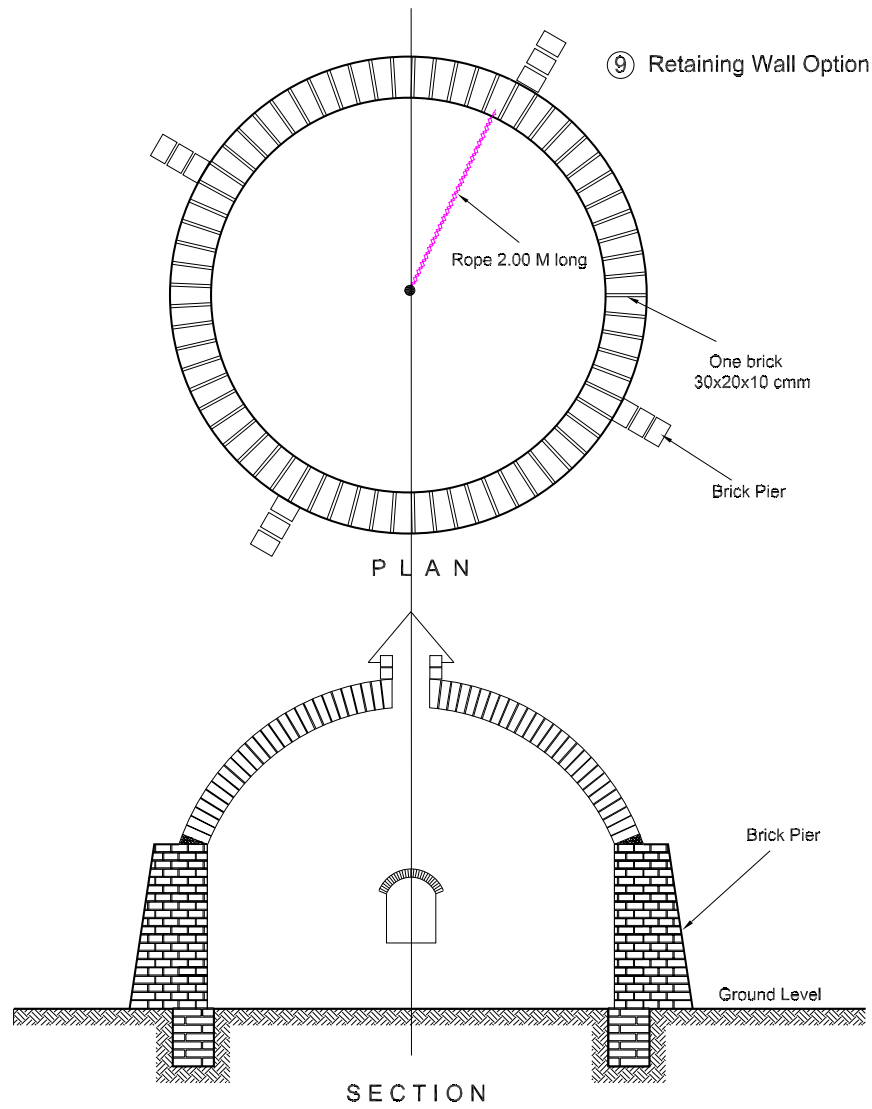

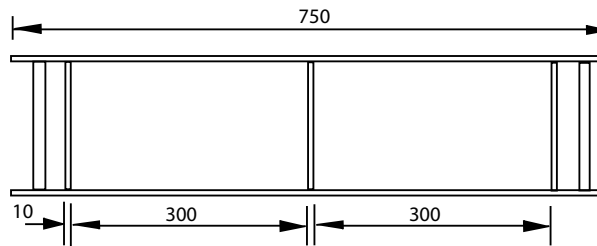
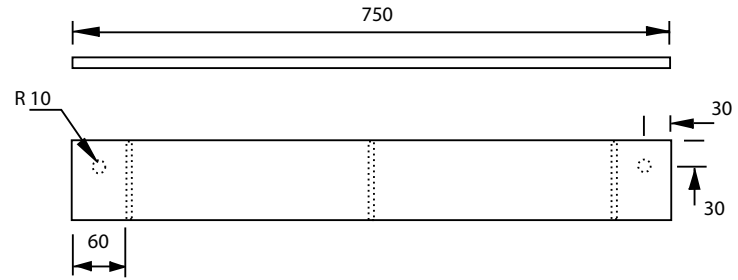
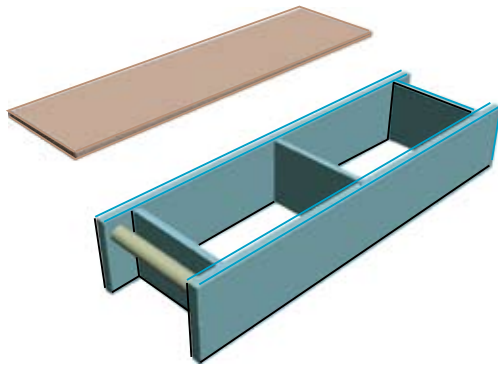
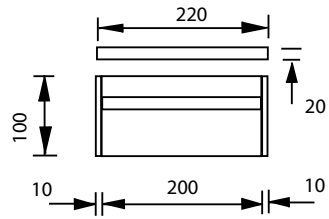



Drawn by Kamal Khalifa	Date: 18 th Dec 2008	All Dimensions in mm	Khartoum Office, Sudan	
The Brick Mould				Drawing No: BM - 01

We recommend you call the office nearest to your location.

Practical Action Sudan - Khartoum Office

Postal address: PO Box 4172, Khartoum 1114.

Street address: #4 street 49 off Pio Yokwan Road - Khartoum W
- Adjacent to and North of Khartoum 3 Sports Club

T: +249- 1- 83 - 578821/ 578827/ 578828 460419.

F: +249- 1- 83 - 472002 .

[Shadia Abdul Moneim - Practical Answers Manager](#)

Tel: 0129133804

Email: shadiaa@practicalaction.org

[Liam Morgan – Technology Promotion and Development Manager](#)

Tel: 0918279293

E-Mail: liamm@practicalaction.org.sd or liamrobmog@hotmail.com

Sudan University for Science and Technology

The Practical Answers Office

Institute for Family and Community Development

[Nour Adeen Mahmoud – Practical Answers Officer](#)

Tel: 0129536435

Practical Action Sudan - Kassala Office

Telephones: 0411822103 / 822699-

Fax: 0411827553-

[Project Officer: Fatima Mahmoud](#)

Tel: 0924615659

E-Mail: fatimaaboualnaga@gmail.com

Practical Action Sudan – North Darfur Office

Telephones: 0731848812 / 843809-

Fax: 0731843809-

[Project Officer: Zakaria Gabbier](#)

Tel: 0122005356

E-Mail: Zicozico2007@yahoo.com

Practical Action – Damazene

Telephones: 0157845180

[Project Officer: Jalal Abu Elgasim](#)

Tel: 0915530610

E-Mail: Jalala@practicalaction.org.sd

Practical Action - Sudan

Postal address: P.O Box 4172, Khartoum 1114
Street address: 4 street 49 off Pio Yokwan Road - Khartoum W - Adjacent to and North of
Khartoum 3 Sports Club
Telephones: +249-1-83- 578821/578827/578828/460419
Fax: +249-1-83-472002
E-Mail: majzoubm@practicalaction.org.sd
websites: www.practicalaction.org