



# SMALL-SCALE COFFEE PROCESSING

## Agricultural and botanical aspects

### Arabica (*Coffea arabica*)

This is a glossy leaved shrub or small tree. The leaves are relatively small and the flowers fragrant and white. Arabica coffee usually receives a premium for its superior flavour and aroma. Arabica is more suited to higher cooler climates eg 600-2000m above sea level and 15-20°C.

### Robusta (*Coffea canephora*)

There are many different Robusta varieties. In general, they can thrive in hotter lowland areas eg below 900m above sea level and over 20°C. Robusta coffee is preferred for instant coffee production due to higher soluble solid extraction.

### Liberica (*Coffea liberica*)

This is a larger tree with large leaves and berries. It can tolerate hot and wet conditions. The coffee produced is bitter. This is preferred in Malaysia and West Asia.

## Harvesting

By definition, 'processing' does not involve harvesting. However, one cannot produce a good product from badly harvested materials. Correct harvesting techniques could be said to be the most important factor in the production of a high quality final product. Correct harvesting is essential. A good coffee cannot be made from poorly harvested coffee cherries.

### Immature harvesting

This is the most serious problem with coffee harvesting. Under-ripe coffee cherries are very difficult to process and a low quality product is produced. One of the main causes of immature harvesting is the fear of theft. If the farmer picks it in an immature state, it prevents the thief stealing it.

### Over-ripe coffee

With over-ripe coffee there is a possibility that the cherry will start fermenting which causes deterioration in flavour.

### Correct harvesting

The coffee cherries should be picked when they are bright red all over. At this stage, the bean can be squeezed out from the pulp by applying light pressure between finger and thumb.

## Processing

There are two ways coffee can be processed - dry ('natural') processing and wet ('fermented and washed') processing. In most cases, wet processing is regarded as producing a higher quality product. However, some areas prefer dry processed coffee for its 'fuller' flavour.

### Dry processing

This is the simpler of the two methods and is popular in Brazil to process Robusta coffee and in Sri Lanka to process Arabica coffee.

### Drying

The coffee cherries are dried immediately after harvest. This is usually sun drying on a clean dry floor or on mats. The bed depth should be less than 40mm and the cherries should be raked frequently to prevent fermentation or discoloration. However, there are problems associated with this method. The most serious problem is dust and dirt blown onto the

produce. Another problem is rainstorms often appear (even in the dry season) with very little warning, this can soak the produce very quickly. Finally, labour has to be employed to prevent damage or theft. Sun drying is therefore not recommended.

**Solar Drying**

Figures 1 and 2 are designs for two solar driers - the solar cabinet drier and the Exell solar drier. The coffee should be placed in the trays in the solar drier. The layer of the crop should be no deeper than one inch (3cm) and it is better if the whole tray area is covered.

The drier should be ready as early in the day as possible so that all possible sunlight hours are used. The coffee should be stirred regularly so that a uniform colouration is formed. At night, the crop should be placed in a cool dry room.

**Artificial driers**

In the wet season solar drying of produce is difficult. Rain is very unpredictable and frequent. Solar driers will prevent the coffee getting wet. However, due to the low level of sunlight, solar drying can take a long time. This can lead to mould growth. An alternative drier is needed.

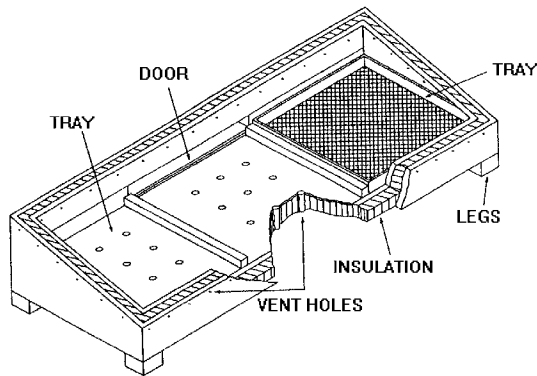

Figure 1: The solar cabinet drier

**Hulling**

The dried cherry is then hulled to remove the pericarp. This can be done by hand using a pestle and mortar or in a mechanical huller. The mechanical hullers usually consist of a steel screw, the pitch of which increases as it approaches the outlet so removing the pericarp.

**Cleaning**

The hulled coffee is cleaned by winnowing.

**Wet processing**

In this method the cherry is squeezed in a pulping machine or pestle and mortar which removes the outer fleshy material (mesocarp and exocarp) leaving a bean covered in mucilage. This mucilage is fermented and dispersed. The bean is washed and dried.

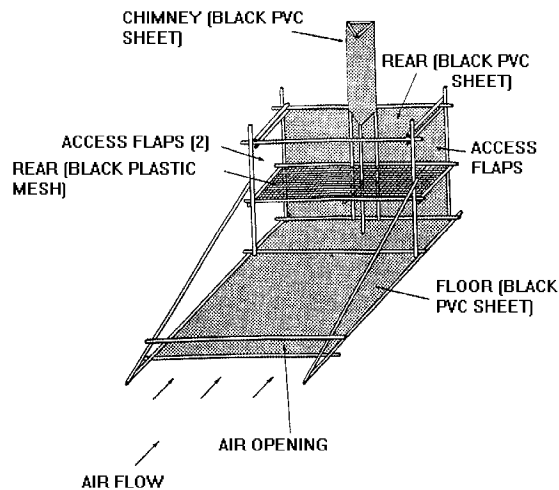

Figure 2: The exell solar drier

**Pulping**

Pulping involves the removal of the outer red skin (exocarp) and the white fleshy pulp (mesocarp) and the separation of the pulp and beans. Immature cherries are hard and green and very difficult to pulp. If the coffee is to be wet processed, correct harvesting is essential.

For small-scale units, the cherries can be pulped in a pestle and mortar, this is very labour intensive.

The two most common pulpers and most suitable for small-scale units are the drum and the disc **pulpers**.

#### Drum pulpers

This involves a rotating drum with a punched sheet surface and adjustable breast plate between which the coffee cherries are pulped, the pulp and the beans separated, see Figure 3. The distance between the drum and the breast plate has to be adjusted so that the pulp is removed without the beans being damaged.

These can be manually operated or attached to a treadle or bicycle. For larger scale units, motorised drum pulpers are available.

#### Disc pulpers

The same concept is involved with the disc pulper. The only difference is that rather than the cherries being squeezed between a breast plate and a drum, a disc with a roughened surface is used.

#### Mucilage removal

The amorphous gel of mucilage around the bean consists of hemicelluloses, pectic substances and sugars and is insoluble in water. This can be removed by chemical methods, warm water or by an 'agua pulper'. However, for small-scale units the only feasible method is fermentation. Fermentation involves the beans being placed in plastic buckets or tanks and left until the mucilage has been broken down. Natural enzymes in the mucilage and feasts; bacteria in the environment work together to break down the mucilage.

The coffee should be stirred occasionally and every so often a handful of beans should be tested by washing them in water. If the mucilage can be washed off and the beans feel gritty rather than slippery, the beans are ready.

The beans should then be washed immediately as 'off' flavours develop quickly.

#### Drying

To prevent cracking the coffee beans should be dried slowly to 10% moisture content (wet basis). Drying should take place immediately after to prevent 'off' flavours developing.

The same drying methods can be used for this as for the dry processed coffee.

#### Hulling

After drying the coffee should be rested for 8 hours in a well ventilated place. The thin parchment around the coffee is removed either by hand, in a pestle and mortar or in a small huller.

#### Cleaning

The hulled coffee is cleaned by winnowing.

#### Roasting

The final flavour of the coffee is heavily dependant on how the beans are roasted. Roasting is a time temperature dependant process. The roasting temperature needs to be about 200°C.

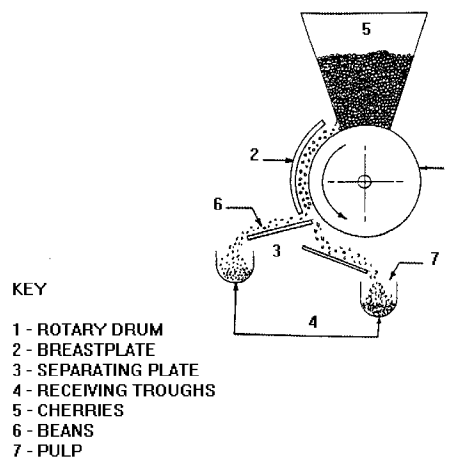

Figure 3: Separation of pulp and beans

The degree of roast is usually assessed visually. One method is to watch the thin white line between the two sides of the bean, when this starts to go brown the coffee is ready. As preferences vary considerably from region to region, a lot of research will need to be done to find the locally acceptable degree of roast.

Coffee beans can be roasted in a saucepan as long as they are continually stirred. A small improvement is made by roasting the coffee in sand, as this provides a more even heat.

A roaster will produce a higher quality product. The simplest roaster is basically a tin can with a handle so that it can be rotated slowly over a fire. There are various other roasters suitable for larger scale units.

### **Grading**

In some cases the crop needs to be graded, eg high quality packaged products for export.

Coffee is graded by size, shape, odour, density and colour. For small-scale units this is best done by hand.

### **Grinding**

Grinding is a means of adding value to a product. However, it is fraught with difficulties. With a whole product it is easy to assess its quality, whereas with a ground product it is very hard.

The fear of adulteration and the use of low quality produce is justified. Because of this there is a great deal of market resistance to ground coffee. This market resistance can only be overcome by consistently producing a good product. There are basically two types of grinders - manual grinders and motorized grinders.

### **Manual grinding mills**

There are many manual grinders that could be used to grind coffee.

An experienced operator can grind about 20kg in an eight hour day. However, this is hard and boring work. A treadle or bicycle could easily be attached to the grinder, which will make the work easier. With this system, one person could grind about 30kg in one day.

Work needs to be done to find out the degree of fineness the consumer wants. The grinding mills then need to be set so that they produce the desired ground product.

For small-scale production (up to 100kg/day) a series of these grinders is all that is needed. For larger scale production units, a motorised grinder would be required.

### **Motorised grinding mills**

Horizontal plate, vertical plate or hammer mills are suitable for grinding coffee. A grinding mill has to be placed in a separate and well-ventilated room because of the dust.

As above, the grinding mill needs to be adjusted so that it grinds the coffee to the desired fineness.

### **Instant coffee**

The production of instant coffee is unsuitable for small-scale enterprises as it requires very expensive machinery eg an extractor and a freeze or spray drier.

A report by the Natural Resource Institute (NRI) states that the smallest economically viable instant coffee factory is 1000 tons/year in India. Various people are trying to design machinery suitable for small-scale production of instant coffee which may be able to reduce the throughput necessary for economic viability.

To produce an instant coffee, the soluble coffee solid and volatile compounds have to be

extracted and then dried into a powder or granules.

### Prestripping

Sometimes the volatile compounds (of which there are over 700) are removed before the extraction of soluble coffee solids. This is usually done by passing steam through a bed of ground and roast coffee. The initial steam pressure has to be high enough for the steam to pass through a static bed of coffee. The extracts and steam are condensed to give a mixture of water and volatile compounds. These compounds can be condensed using a tubular condenser with chilled water flowing through it.

### Extraction of soluble coffee solids

The extraction of soluble coffee solids is usually done using water as the solvent. Extraction is continued until the solution obtained is 15-25% w/w. The extraction is usually done at 175°C since at 100°C the extracted solids are difficult to dry. There are three ways the solids can be extracted.

#### Percolation batteries

This is the most common method. The roast and ground coffee is held in a series of 5-8 vessels. Hot water is passed through the vessels and, when the soluble coffee solids have been fully extracted from each vessel, it is isolated from the battery and spent coffee discharged. A new vessel replaces this exhausted vessel, see Figure 4. As the extraction takes place at 175°C, the system needs to be under pressure. A solution of 15-25% w/w solubles is produced which can then be dried.

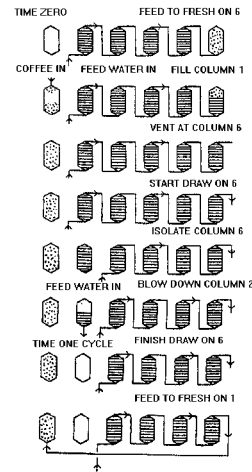

Figure 4: Percolation batteries

#### Countercurrent system

Coffee is fed continuously into the bottom of an inclined cylindrical vessel and moved upwards by two helicoidal screws rotating at 10-22 revolutions per hour. Hot water enters the top and the extracted solids in, solution comes out the bottom. The vessel is pressurised and kept at 180°C by the use of temperature jackets.

This is even less suitable for small-scale production as it is 40% more expensive than the percolation battery system.

#### Slurry extraction

Coffee and water are agitated together in a tank and separated using a centrifuge. The machinery for this is also very expensive.

#### Drying

The extracts can be dried in a spray drier, freeze drier or a drum drier.

#### Spray drying

Spray drying requires that the concentrated coffee solutions extracted are 'atomised' to form droplets (10-200 micrometers in diameter) and then sprayed into a current of heated air (150-300°C) in a large drying chamber, this is usually a concurrent air flow.

Complete and uniform atomisation is required. For coffee drying, a centrifugal atomiser is usually used. The liquid is fed to the middle of a rotating bowl (peripheral velocity of 90-200m/s). This produces droplets with diameters of 50-60 micrometers in a uniform spray.

technical brief

The droplets are dried very rapidly (1-10 seconds) due to the very large surface areas. The dry powder is removed from the base by a screw conveyor or a pneumatic system.

Spray driers are very expensive and can have high energy costs.

### **Freeze drying**

Freeze drying takes place by sublimation (ie liquid turning to vapour). The liquid is slowly frozen in conventional freezing equipment. The frozen material is put under pressure (610pa) and heated. As long as the pressure in the freeze drier is below the vapour pressure at the surface of the material, it will sublime directly to vapour without melting. The vapour needs to be removed by a vacuum pump and condensed on refrigeration coils. The final drying stage involves evaporative drying (desorption). This is achieved by raising the temperature to near ambient whilst retaining the low pressure.

Coffee needs to be frozen as a foam (by gas inclusion) to prevent formation of a glassy vitreous frozen material.

All the equipment available for freeze-drying (eg contact freeze driers, accelerated freeze driers and microwave freeze driers) is very expensive.

### **Drum drying**

This is rare nowadays. It involves the extracts being dried by coming into contact with a heated cylindrical surface.

## **Packaging**

### **Packaging material**

Packaging of coffee especially if it is ground requires polypropylene. Polythene cannot be used as the flavour components diffuse through it. The use of laminates is popular but more expensive.

### **Simple sealing**

The bags can be sealed simply by folding the polypropylene over a hacksaw blade and drawing it slowly over the flame of a candle. However, this is extremely uncomfortable as the hacksaw blade heats up and burns the hands of the operator.

### **Sealing machines**

A sealing machine will speed up this operation considerably and produce a much tidier finish (which is very important).

The cheapest sealing machines have no timing mechanisms to show when the bag is sealed and they have a tendency to overheat.

Sealing machines with timers are desirable. The machines come in many sizes. For most work an eight inch (20cm) sealer is sufficient.

Eye catching labels should be sealed above the product in a separate compartment and holed so that the package can be hung up in the shop.

### **Storage**

A well designed and secure store is essential.

The optimal conditions for a store are a low temperature, low humidity and free from pests. The store should be located in a shaded, dry place. To keep humidity as low as possible only fully dried products should be stored in it. The produce should be checked regularly and if it has absorbed too much moisture it should be dried again.

To prevent pests entering, the roof should be completely sealed. Mosquito netting should be placed over the windows, and the doors should be close fitting.

## Coffee processing waste

### Coffee pulp

If not treated, this will give rise to unpleasant odours and attract flies and insects. It can be converted into animal feed, soil conditioner, or used for caffeine extraction and biogas production.

### Waste water

Care needs to be taken to prevent water from the processing, polluting local rivers or lakes.

## Equipment suppliers

Note: This is a selective list of suppliers and does not imply endorsement. by Practical Action

John Gordon Co Engineers Limited Hillcrest House  
4 Market Hill  
Maldon  
Essex  
CM9 4PZ  
UK

Tel: +44 (0) 1621 858944

Fax: +44 (0) 1621 857733

E-mail: admin@johngordon.co.uk

- Winnow. Capacity: 15-45 kg/hour. Power: Electric.
- 'Irima 67' Disc Pulper Coffee Pulpers used for depulping coffee cherries. Capacity: 270-360 kg/hour Power: Manual
- 900TD Wooden Frame Testing Screens used for the size classification of green coffee beans.
- Small Scale Coffee Roaster used for roasting batches of coffee beans but can also be used for roasting cashew nuts, peanuts, almonds etc. Power: Electric.
- Bukoba Coffee Huller. The shelled coffee is discharged at the end of the machine mixed with the shells and dust and must then be winnowed and sieved. Capacity: 9-27 kg/hour. Power: Manual

Alvan Blanch Chelworth  
Malmesbury  
Wiltshire  
SN16 9SG  
United KingdomK

Tel: +44 (0) 666 577333

Fax: +44 (0) 666 577339

- Coffee Huller, used for the hulling of coffee. Power: Diesel/Petrol/Electric.
- Coffee Pulper. 300-4000 kg/hour Power: Manual/Electric/Diesel/Petrol
- Coffee Grinder KF1800 used for the grinding of coffee after roasting.
- Coffee Roaster. Capacity: 100 kg/hour of Power: Gas/Electric

Denlab International (UK) Limited Hillcrest House  
4 Market Hill  
Maldon  
Essex  
CM9 4PZ  
UK

- Coffee Pulpers used for depulping coffee cherries. Easily adjustable to accommodate all types of coffee. Capacity: 300 kg/hour Power: Diesel/Electric/Manual/Petrol

Rajan Universal Exports Manufacturers PVT Limited Post Bag  
No. 250  
162, Linghi Chetty Street  
Chennai - 600 001  
India

Tel: +91 44 5341711 / 5340731 / 5340751 / 5340356

Fax: +91 44 5342323

- Coffee Pulper / Drum Pulper used for pulping coffee beans on a small-scale. Capacity: 300 kg/hour Power: Manual/Electric

Gauthier  
Parc Scientifique Agropolis  
34397 Montpellier  
Cedex 5  
France

Tel: +33 (0) 4 67 61 11 56

Fax: +33 (0) 4 67 54 73 90

- **Decorticator / Husking Machine** - DQC 500. Other seeds can also be treated, e.g. groundnuts, almond. Capacity: 500-1200 kg/hour

Marot Agro-alliance  
BP 72  
60304 Senlis cedex  
France  
Telephone: +33 03 44 60 03 00  
Fax: +33 03 44 53 21 60

- Sizing Equipment for coffee and cocoa.

Invensys APV  
23 Gatwick Road  
Crawley  
W Sussex  
RH10 9JB  
United Kingdom  
Freephone : 0800 328 2211  
Tel: +44 (0)1293 527777  
Fax: +44 (0)1293 552640  
<http://www.apv.invensys.com/>

#### Equipment for the production of Instant Coffee

W M McKinnon & Company Limited  
18 Primrose Hill Ave  
Coults  
Aberdeen  
AB15 9NL  
United Kingdom  
Tel: +44 (0)1224 863828  
Fax: +44 (0)1224 863828

- Coffee hullers
- Powdered coffee pulpers

Technonet Asia Model  
Technonet Asia  
U P Institute for Small Scale Industries  
Phillipines  
Website: <http://www.upissi.ph.net/>

- Coffee roasters

Gurdeep Packaging Machines Harichand Mill  
Compound  
L.B.S.Marg  
Vikhroli  
Mumbai - 400 079  
India  
Tel: +91 (0)22 2578 3521/ 2577 2846/2579  
5982 Fax: +91 (0)22 2577 2846

- Form Fill Seal Machine for sachet/pouches from heat sealable laminate. Used for packing free flowing powder, granules, spices, tea, coffee etc.

Udaya Industries Uda Aludeniya  
Weligalla  
Gampola  
Sri Lanka  
Tel: +94 8 388586  
Fax: +94 8 388909

- Coffee pulper, can also be used for neem and ground nuts.  
Capacity: 40 kg/hour

Maschinenfabrik Ferd. Gothot GmbH  
Postfach 100447  
D-464224 Emmerich  
Tel: +49 2822 2021  
Fax: +49 2822 912 444  
E-mail: [info@gothot.com](mailto:info@gothot.com)  
Website: <http://www.gothot.com>

- Coffee roasters

Sri Venkateswara Industries C-37, Industrial Estate  
Yadavagiri  
Mysore - 570 020  
India  
Tel: +91 (0)821 2514 828 / 2443310

- Coffee roasters, grinders and mixers for coffee making.

Industrias Technologicas Dinamicas S A Av.  
Los Platinos 228  
URB. Industrial Infantas  
Los Olivios  
Lima  
Peru  
Tel: +51 14 528 97 31  
Fax: +51 14 528 15 79

- Tea-bag filling machine. The machine can be used for a range of products, including tea, coffee and herbal teas.  
Capacity: 70-120 bags per

# technical brief