

# Best Practice in Small-Scale Gemstone Mining

DFID Knowledge and Research Project

## DRAFT

# INFORMATION AND SOURCE MATERIAL ON GEMSTONE IDENTIFICATION AND VALUATION



July 2003

itc

projekt  
consult

UNICEF  
SITAT  
MAINE

ITDG  
PRACTICAL ANSWERS  
TO POVERTY

## **Disclaimer**

This project is an output from a project (R7115) funded by the UK Department for International Development (DFID) for the benefit of developing countries. The views expressed are not necessarily those of the DFID.

## **Contributing Authors**

### **Dr. Tobias Häger**

Dr. Tobias Häger studied mineralogy at the Johannes Gutenberg-University of Mainz. He focused his PhD research on gemstone and gemmology. Whilst working as a scientific assistant at the Department of Gemstone Research, University of Mainz, he is also involved in several projects concerning gemstone enhancement and heat treatment. He has worked on projects in cooperation with the ceramic industry in Germany, and has experience of the heat treatment of rubies and sapphires, and quality control issues in Thailand, Sri Lanka & Vietnam. Recently he analysed the trade and export situation, and the treatment of gemstones from Madagascar.

### **Dr. Michael Priester**

Dr Michael Priester is a mining engineer and a partner and head of the mining department of Projekt-Consult GmbH in Königstein, Germany. He has accumulated extensive experience in small-scale mining in developing countries on commissions from the GTZ, BGR, the Swiss Government, the European Community, organisations of the UN-System and the World bank. He has worked in Australia, Bolivia, Botswana, Brazil, Central African Republic, Chile, Colombia, Ecuador, Ghana, Peru, Philippines, The Gambia, Venezuela, Zambia, Zimbabwe. From early 2000 to 2002 he acted as lead consultant for the ATPM project in Madagascar advising small-scale gemstone miners.

### **Dr. Mahinda S. Rupasinghe**

Dr. Rupasinghe is a professional gemmologist from Sri Lanka. After graduating from the Universities in Johangeorgenstadt and Berlin, Germany in Hydrogeology, Geology and Mineralogy he completed postgraduate study at the Institute for Gemstones at the Johannes Gutenberg University in Mainz, Germany. Back in Sri Lanka, after a stay in Abu Dhabi, he now works at the University of Buttala as Gemmology Professor. He is regarded as a senior expert on Sri Lankan gemstone geology and gemmology.

### **Heather Mackay**

Heather is a social scientist and the Sustainable Livelihoods Project Manager at ITC and the person responsible for this Best Practice in Small-scale Gemstone Mining project. She has worked extensively in West Africa on social development projects, and the socio-economic impact of resettlement due to gold mining in Ghana, and is currently contributing to a paper on the livelihood impact of price fluctuations on small-scale mining communities. Her skills include social assessment and evaluation; participatory methodologies; environmental policy and resource management; and sustainable livelihoods analysis.

## Preface

# Historical Perspective to Sri Lanka's Gemstones

Sri Lanka has been famous for its gems for thousands of years. Ancient chronicles and records noted the abundance of exquisite gems unearthed from the land of "Rathna dweepa" (Island of gems), the name given to Sri Lanka. Arabs and Persians were engaged in profitable trade with the East and Sri Lanka's gemstones were among the most valuable commodities. The "jewels of Serendib" were in fact those from Sri Lanka and the name Serendib was identified with the Island. Beryls, sapphires, rubies, garnet and topaz were some of the gem minerals mentioned in the travelers' records.

The most noteworthy feature of these documents was the reference to the variety and abundance of the gemstones of Sri Lanka. The truly high quality gems of Sri Lanka were reflected, literally, in some of the priceless jewels of the Kings and Queens of England. The blue sapphires of Sri Lanka have gained universal fame for their magnificent quality. Yet, in spite of hundreds of years of gem mining, the traditional techniques that were employed in the process of mining remain unchanged. It is perhaps due to this fact alone that Sri Lankan gem reserves are still quite significant.

In the recent history of gem mining in Sri Lanka the gem industry assumed the status of a major foreign exchange source. However, illicit mining and smuggling of gems into other countries caused serious setbacks to the industry and the much-

wanted foreign exchange was lost to the country.

With the establishment of the State Gem Corporation in 1971 certain useful steps were taken to develop the gem industry.

The large scale buying of geuda and subsequent heat treatment, mostly by Thai traders, had a major impact in the gem industry. In 1987 the State Gem Corporation took the geuda trade under its wings and a bilateral agreement between Thailand and Sri Lanka was signed. *Geuda is a technical term used in the trade in Sri Lanka and describes a greyish sapphire material which can be heat treated to add value. The greyish colour is due to small rutile inclusions.*

Any kind of mining results in environmental degradation and Sri Lanka's gem mining was no exception. The large numbers of illicit gem pits dug over the last few decades have caused serious concern among environmentalist and strong laws have been passed to try to halt the alarming rate of land degradation through gem mining. Whether these laws are effectively implemented and enforced is a different story.

# CONTENTS

<b>1</b>	<b>INTRODUCTION TO THE MATERIAL.....</b>	<b>7</b>
<b>2</b>	<b>INTRODUCTION TO GEM VALUATION &amp; ENHANCEMENT.....</b>	<b>9</b>
2.1	Steps to Follow to Assess the Value of a Gem.....	9
2.2	Gemstone Enhancement Potential .....	9
<b>3</b>	<b>IDENTIFICATION OF GEMS USING PHYSICAL PROPERTIES.....</b>	<b>11</b>
3.1	Hardness.....	11
3.2	Density .....	12
3.3	Refraction of Light.....	15
3.4	Minerals with different colours in different directions .....	18
<b>4</b>	<b>GEMSTONE ENHANCEMENT POTENTIAL .....</b>	<b>19</b>
4.1	Gemstone Enhancement - Heat Treatment .....	19
4.1.1	The Principles of Heat Treatment (for ruby and sapphire) .....	19
4.1.2	How to evaluate a sapphire for heat treatment .....	22
4.1.3	Positive inclusions for the heat treatment of sapphires .....	22
4.1.4	Neutral inclusions for the heat treatment of sapphires .....	24
4.1.5	Negative inclusions for the heat treatment of sapphires .....	25
4.2	The treatment process for rubies and sapphires.....	27
4.3	Gemstone enhancement – identification of a heat treatment.....	28
4.4	Gemstone Enhancement – Cutting.....	29
4.4.1	Principles of cutting .....	29
4.4.2	Direction of best colour.....	31
4.4.3	Inclusions .....	34
4.4.4	How to position inclusions in the cut stone?.....	34
4.4.5	Positive inclusions.....	35
4.4.6	Cleavage .....	36
4.4.7	Colour zoning .....	36
4.5	Calculation of the weight of a cut stone .....	37
<b>5</b>	<b>ASSESSMENT OF A GEM’S VALUE.....</b>	<b>39</b>
<b>6</b>	<b>HOW TO OPTIMISE YOUR GEMSTONE SALES .....</b>	<b>41</b>
<b>7</b>	<b>EXPORT AND TRADE.....</b>	<b>43</b>

## **LIST OF ANNEXES**

Annex 1 – Identification of Gemstones (Cue Cards)	9 pp
Annex 2 – Table of Gem Properties	2 pp
Annex 3 – Suppliers of Equipment and Important Literature	1 p

# 1 Introduction to the Material

As part of the DFID-funded research project on small-scale gemstone miners (R7115) an information and training needs assessment was undertaken in Sri Lanka in 1999 (project report by Dr Amarasinghe, 1999). Based upon the results of this study a specific training course was developed and implemented. The resulting information and source material for training is presented in this document. The content of the material was dictated by the list of topics requested by the small-scale miners as their key information and training needs.

The needs assessment confirmed that a key concern of miners was for training on the valuation of gemstones (the assessment of price value). No such material is easily available to miners, particularly not in the local language. While miners would like to have a tool allowing the specification of a price for each stone the marketing environment for coloured gemstones is difficult and involves a number of rapidly changing parameters, such as fashions regarding colour, and general price highs and lows according to the world gem production. Nevertheless this material incorporates the most recent knowledge of factors that influence the value of a gem and provides important guidance on how miners can assess the value of their gems more accurately.

This material was tested and evaluated at a training workshop held in Ratnapura and oriented further to the miners' needs and interests. The documents is available in English and Sinhala and aims to help small-scale gemstone miners to better assess the value of their gems, and therefore to obtain a fairer price from dealers and traders. The manual will also help miners to overcome the lack of technical information available to them in their own language.

The material presents as much practical information and advice as possible on the gem identification process. It provides detailed descriptions, with illustrated examples, of how gemstones are enhanced by cutting, polishing, heat treatment, crack filling etc, throughout their journey from the mine to the final point of sale to a customer as a jewel or collectors item. The document provides six different sections covering the following topics (these 'information packs' can be used as source material for training events, adapted to the audience's needs):

## **FACTORS THAT INFLUENCE A GEM'S VALUE**

- **Identification of Gemstones**
- **The Gem Enhancement Techniques**
- **Assessment of a Gem's Value**
- **Optimising Gem Sales**
- **Background Information on Gem Export and Trade**

This information will provide small-scale miners with a greater understanding of the value a gem can obtain and will arm them with the knowledge they need to ensure that the prices they attain for their gems are a fair reflection of the end market value of that gem. The material is intended as a tool to raise awareness of the wider chain into which their gem mining activity fits rather than as a detailed procedural manual allowing miners to add value to the gems themselves.

## 2 Introduction to Gem Valuation & Enhancement

### 2.1 Steps to Follow to Assess the Value of a Gem

The valuation of gem material follows a number of steps, starting with the **identification**. After the identification procedure you need to focus on estimation of the potential for the gemstone to be enhanced in order to increase its value. Gems may be enhanced by using several physical and / or chemical processes like **heat treatment** and by the cutting process. The heat treatment process is described below in order to allow an estimation of your gem's potential value to be added by heat treatment.

In the next step you have to learn a bit about gem **cutting** in general before you will be able to evaluate the cutting potential of your gem.

In the last step of valuing a gemstone you need to estimate the **weight** of the material after the cutting process.

It is essential that you pay attention to all these factors:

- Identification
- Heat Treatment Potential
- Cutting Potential
- Weight

before you can attempt to assess the price of your gemstone. The following chapter describes how to assess each of these qualities in your gem mineral.

### 2.2 Gemstone Enhancement Potential

The value of a gemstone is determined by the famous 4 big C's:

- Colour
- Clarity
- Cut or shape (or the potential for cutting)
- Carat (or the carat after cutting)

All these factors might be influenced and enhanced on the journey from the rough material to the cut gem. It is possible to influence these 4 C's with several physical and/or chemical methods as shown in Table 1:

---

<sup>1</sup> Geuda is a technical term used in the trade in Sri Lanka and describes a greyish sapphire. The greyish colour is due to small rutile inclusions.

**Table 1: Techniques to Enhance the Natural Characteristics of a Gem**

Characteristic	Enhancement Techniques
Colour	Cut, heat treatment, new heat treatment, diffusion treatment, dyeing of porous and cracked materials, irradiation
Clarity	Cut, heat treatment, laser drilling, filling of cracks with: colourless oils, hardening organic and inorganic substances
Shape	Cut, crystal growth
Carat	Cut, Doublet, Triplet, crystal growth

By cutting a gemstone it is possible to influence the colour (choice of the direction of best colour and cut of the right angles and proportions), the clarity (inclusions can be cut away) and of course the shape or the cut (to increase the brilliance). Therefore this important topic will be discussed in more detail in section 4.4.

It is possible to enhance the clarity of a gemstone by filling the fractures with organic (oil, resin and so on) or inorganic (glass) substances. Equipment for the crack filling of emerald is shown in Figure 1. On the heating unit a pressure cylinder is positioned. On the top of the pressure unit a manometer can be seen. The emeralds and the chosen oil are positioned in the pressure unit. When the pressure unit with the stones inside and the oil is properly closed the unit will heat up to a certain temperature and pressure. The oil will then be pressed into the cracks of the stone and make the stone look smooth and clear.



**Figure 1: Equipment to fill cracks in emerald with organic substances**

It is not necessary to declare oiling of emerald and the classical heat treatment, but other treatments like irradiation and the filling of cracks with coloured oils and glasses have to be declared. More information on classical heat treatment is given in section 4.3.

### 3 Identification of Gems using Physical Properties

To identify the gem material you need to assess the physical properties of the stone such as:

- the Hardness
- the Density
- the Refraction of Light
- the Direction of Colour

It is cheap and easy to carry out these physical investigations, as the following sections describe.

#### 3.1 Hardness

One easy and cheap method to determine the kind of gemstone is to test the hardness. Most of the gemstones differ in their hardness. There are different ways to check the hardness. The easiest way is to scratch the sample with a mineral of known hardness.



**Figure 2: Set of pocket hardness scale**

Today hardness sets are available (see Figure 2). But it is also possible to make your own hardness set out of the minerals which are very common in Sri Lanka using the following table as a guide:

<b>Mineral</b>	<b>Hardness</b>
Moonstone	6
Quartz	7
Topaz	8
Chrysoberyl	8.5
Ruby/Sapphire	9
Diamond	10

You can use the hardness set very easily. You start with the hardest mineral to scratch the surface. Rub the powder on the surface away and check whether the surface is scratched or not. Try all others successively to the point where the first mineral of known hardness does not scratch the surface. The test stone therefore has the same hardness as this mineral

The surface of mineral in Figure 3 was scratched with the hardness of 8.5. With the hardness of 8 it was not possible to scratch the surface. The mineral therefore has the hardness of 8. If you look up the Mineral properties table in Annex 2 at the end of this manual you will see that a hardness of 8 indicates that it is likely to be a spinel and not a ruby.



**Figure 3: Surface were scratch with a mineral of hardness of 8.5**

### **3.2 Density**



Another very important property of gemstones is the density, which means the weight per volume. In most cases it is in the units of gramme per cubic centimetre (cm<sup>3</sup>). So if we have a certain gemstone cut as a cube of the size of 1cm to 1 cm to 1cm, we just can measure the weight of this cube and that value will be the density of this cube.

In most cases rough gemstones have an irregular shape therefore we have to calculate the density of the samples by taking two measurements and calculating the balance. At first we have to determine the weight of the stone in air and then we have to measure the weight of the sample in a liquid of a known density. In most cases the best liquid is pure water with just a drop of liquid soap in it.

Before we start the procedure of density determination we have to clean the sample and have to remove oil and foreign substances like soil from the surface. After cleaning we have to determine the “normal” weight of the sample in air. This step is shown in Figure 4. The determined weight is 4.15 ct.

In the next step the weight of the basket in water must be measured. Please pay attention that no air bubble is adhering on the basket. If there are any air

bubbles shake the basket gently to loosen the bubbles. The weight is 4.02ct (see Figure 5).

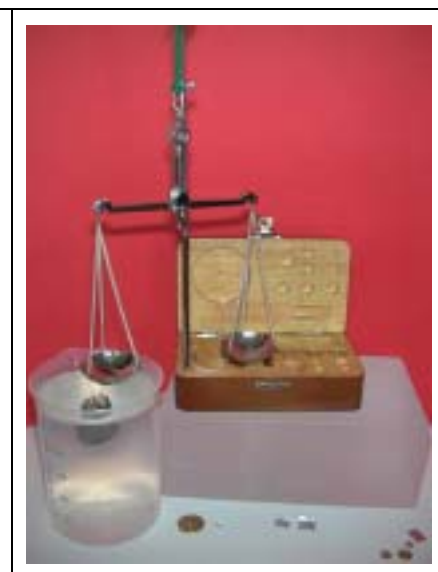
		
<p><b>Figure 4: Determination of the weight of a sample</b></p>	<p><b>Figure 5: Determination of the weight of the “basket” in water</b></p>	<p><b>Figure 6: Determination of the weight of the sample in water with the basket</b></p>

In the next step we have to determine the weight of the stone with the basket (see Figure 6). Please pay attention again that no air bubble adheres to the stone. The weight of the stone and basket in water is 7.14ct.

Now we have to subtract the weight of the basket (4.02ct) from the weight of the basket with the stone (7.14ct).

$$7.14 \text{ ct} - 4.02 \text{ ct} = 3.12 \text{ ct}$$

The result is the weight of the stone in water (3.12ct)! This value and the weight of the stone in air have to put into the following formula:

$$\text{density..of..the..sample} = \frac{\text{weight..in..air}}{\text{weight..in..air} - \text{weight..in..water}} * \text{density of the water}$$

The density of the water depends on the Temperature (see the following table). During this experiment the temperature was 20°C.

Temperature °C	15	16	17	18	19	20	21	22	23	24
density in g/ml	0,9991	0,9990	0,9988	0,9986	0,9984	0,9982	0,9980	0,9978	0,9976	0,9973

Temperature °C	25	26	27	28	29	30	31	32	33
density in g/ml	0,9971	0,9968	0,9965	0,9963	0,9960	0,9957	0,9954	0,9951	0,9947

$$\frac{4.15ct}{4.15ct - 3.12ct} = \frac{4.15ct}{1.03ct} = 4,03 * 0,9982g/cm^3 = 4.022 g/cm^3$$

So, the density of the sample is 4.022g/cm<sup>3</sup>. This value is typical for corundum (ruby, sapphire, geuda, ottu, young geuda and so on).

Now we want to compare this result with the values determined by a high tech digital balance.

At first we have to determine the weight of the stone in air again.



**Figure 7: Weight of the stone in air**



**Figure 8: Weight of the stone in water minus the weight in air**

For the second example we take the same stone and determine its weight by a digital balance. As you can see in Figure 7 the weight of the stone is 4.163ct.

After this step we recalibrate the balance with the stone on it and then put the stone into the “basket in water. The value -1.032ct (see Figure 8) is therefore the weight of the stone in water minus the weight of the stone in air. Now we put these two values again into our formula:

$$\text{density..of..the..sample} = \frac{\text{weight..in..air}}{\text{weight..in..air.} - \text{weight..in..water}} * \text{density of the water}$$

$$\gg \frac{4.163\text{ct}}{1.032\text{ct}} = 4,034 * 0,9982\text{g/cm}^3 = 4.027 \text{ g/cm}^3$$

So in fact, the difference between the earlier method and this is just 0.005 g/cm<sup>3</sup>. This value is negligible and is due to the kind of measurement. The cost of the classical balance scales is round about US \$50 and the coast of the digital one about US \$2,000. The process to measure the density with the digital balance is a little bit more comfortable and a little bit more precise, but the classical balance technical also works very well too.

### 3.3 Refraction of Light

The way in which a gemstone refracts light through itself is another physical property which is used to identify gem minerals. The most suitable method for assessing the refraction of light is by using a refractometer. The working principle is as follows: If light goes from air into a more dense material like a gem the light will change a little bit its direction (see Figure 9).

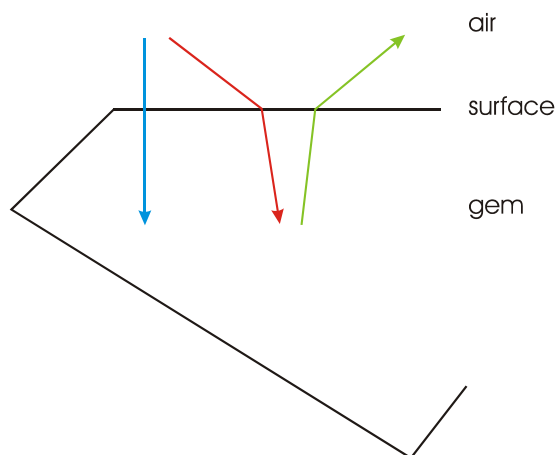

**Figure 9: Refraction of light**

The change in the direction of the light is called refraction. With increasing difference in the density of the materials the refraction increases. These values are called **refractive indices**. Refractive indices are very characteristic for all gem material. In Figure 10 a diagram of a refractometer is shown. Typical refractive indices of gems are shown in Annex 2 at the end of this manual.

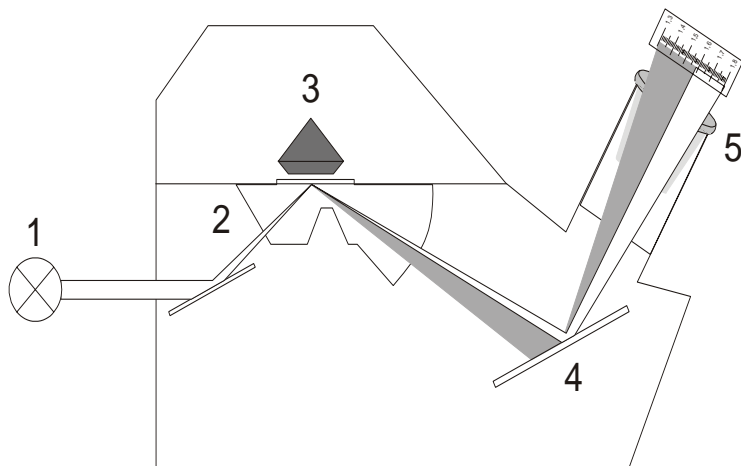

**Figure 10: Diagram of a refractometer**

Key:



- 1 = light source with just one certain colour
- 2 = Glass of high refractive index
- 3 = Gem sample
- 4 = Mirror and scale
- 5 = Filter

To learn how to work with a refractometer, let us start with a practical example. At first we have to put a little bit of refractometer fluid on the glass body. In the next step we put our red stone on the glass (see Figure 11).



**Figure 11: Red stone on a refractometer**

Now we look into the refractometer and see a border between a bright and a darker area. This border gives us the refractive index of our red stone. In our example the value is 1.620 (see Figure 12).

	
<p><b>Figure 12: First refractive index of the red stone is 1.620</b></p>	<p><b>Figure 13: Second refractive index of the red stone is 1.640</b></p>

Now, if we turn the filter (see diagram in Figure 10), the border of the bright and the dark area will vary and we will see a second value of 1.640 (see Figure 13). Then we have to turn the stone some degrees and turn the filter again. The high value will be the same but the lower one will increase. The maximum difference between the highest and the lowest value is 0.02. This is what is called **birefringence**. In other words the refractive indices are 1.620 and 1.640 and the birefringence is 0.02. These values in combination with the colour are typical for Tourmaline. As you know there are plenty of Tourmalines therefore these values vary very strong, but all other minerals in Annex 1 and 2 do not have these values. The closest minerals are Hemimorphite and Amblygonite, but nevertheless with a lower refractive index! To verify these values other facets of the stone should be analysed.

In addition to that, according to the behaviour of a stone on the refractometer more information about the physical property of the stone can be deduced and groups can be found.

- 1) Minerals of the first group (like spinel, garnet) show the same refractive index in all directions, even if we turn the sample, the filter or chose another polished surface (facet).
- 2) Minerals of the second group have one index which does not change, if we turn the filter and the sample and the second vary. If the high value is the stable one, we say the stone has one axe and is negative. If the low index is the stable one it has again one axe, but it is positive. See annex 1 and 2.
- 3) In the third case both refractive indices vary, if we turn the stone and the filter. If we calculate the average of all measurements and this average is closer to the highest value the stone has two axes and is negative. If the average is closer to the lower value the stone has two axes and is positive. See annex 1 and 2.

So if we transfer this new knowledge to the tourmaline mentioned above, tourmaline has one optical axis negative. Those values are also typical for tourmaline. See annex 1 and 2.

Just with these simple measurements we are able to identify all minerals which have a refractive index below 1.81. Minerals with a higher index like Diamond, Zircon and some garnets can not be identified with this method.

The cost of such a refractometer is between US \$250-800. The disadvantage is we need at least one polished surface (facet).

### 3.4 Minerals with different colours in different directions

If a mineral shows different colours in different directions (see Figure 37), this property can help us to identify the mineral. Usually a piece of equipment know as a dichroscope is used (see Figure 14). With the dichroscope you can check very easily if a sample shows different colours in different directions or not. It is possible to differentiate very quickly between, for example, ruby and spinel. In the case of ruby we can recognise in most directions two colours and in the case of spinel there is only one colour.

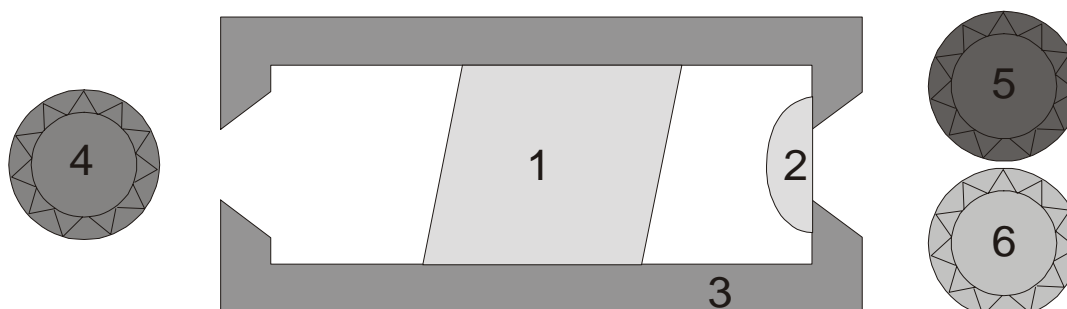

**Figure 14: Sketch of dichroscope**

**Key:**

1 = Calcite

2= Lens

3= Tube-like box

4= Gem sample

5 and 6 = Two pictures of the gem sample showing the two colours

## 4 Gemstone Enhancement Potential

### 4.1 Gemstone Enhancement - Heat Treatment

#### **The Principles of Heat Treatment (for ruby and sapphire)**

The low temperature heat treatment of ruby has a long tradition in Sri Lanka. This technique is used especially to eliminate a blue hue from rubies and some pink sapphires. Fire, produced by burning charcoal or coconut shell was used, and bellows were used to increase the temperature. This technique is still used today, but instead of bellows a blower is used (see Figure 15).



**Figure 15: Traditional heat treatment in Sri Lanka**

In the beginning of the 1970s Thai -gem dealers developed the high temperature treatment. This high temperature treatment was done using diesel and gas furnaces. One gas furnace developed in Sri Lanka is the famous LakMini furnace<sup>2</sup> (see Figure 16). The maximum temperature is between 1800 and 1900°C depending on the components.

---

<sup>2</sup> The cost of such a furnace is US\$1,500.



**Figure 16: High temperature gas furnace made in Sri Lanka owned by Prof. Rupasinghe University of Buttala**

The advantages of such a furnace are the low primary cost and the low gas cost. The disadvantages are the cost of pure oxygen and the lack of temperature control.

Today even electrical resistance furnaces with Super Kanthal 1900 heating elements are used. The maximum temperatures of such furnaces are round about 1800 to 1850°C. The cost of such a furnace is US\$16,000. The advantage is the fully controllable treatment programme and the comfortable use of such furnaces. The disadvantages are the high primary costs and secondary costs of the heating elements (US\$350-400 ).

The first scientist who published a detailed description of the treatment process was Nassau, (1984, 1994). With the concept of Nassau many reactions were explainable, but not all. For example Nassau pointed out, that all blue Sapphires have to be treated in reducing<sup>3</sup> atmospheres to produce the blue colour.

In the Figure 17 you see two rows of samples. Every stone was cut into two pieces. The upper part of each sample was heat treated in air up to 1800°C for 15 hours to develop the yellow and the blue colour. As you can see in Figure 17, the oxidising atmospheres<sup>4</sup> also lead to the intensification of the blue colour.

---

<sup>3</sup> Reducing atmosphere means with an excess of gas in the gas to oxygen ratio. If you run such a process in a furnace inside a house be sure, that it is enough air circulation in the room!!!

<sup>4</sup> Oxidising atmosphere means in air or with an excess of oxygen in the gas to oxygen ratio



**Figure 17: Samples from the Getaheta, Rantapura and Buttala area heat treated at 1800°C in air**



**Figure 18: Samples from the Getaheta, Rantapura and Buttala area heat treated at 1800°C in air**



**Figure 19: Samples from the Getaheta, Rantapura and Buttala area heat treated at 1800°C in air**

### **How to evaluate a sapphire for heat treatment**

If a sapphire will show a better colour and a better quality after heat treatment or not depends very strong on the kind inclusions<sup>5</sup>. Therefore if you want to evaluate the potential for heat treatment, we have to look on the inclusions in detail.

How to find the inclusions is shown in chapter 0. But what is the role of these inclusions during the heat treatment? Inclusions can be divided into 3 groups:

1. Positive inclusions for the heat treatment (see chapter 0)
2. Neutral inclusions for the heat treatment (see chapter 0)
3. Negative inclusions for the heat treatment (see chapter 0)

### **Positive inclusions for the heat treatment of sapphires**

The inclusions of the first group indicate a positive reaction of the corundum in the heat treatment process.

Rutile<sup>6</sup> inclusions in right concentration belong to this group. Rutile is dissolved in lattice and is responsible for the intensification of the blue colour during the treatment process. The size and the concentration of these inclusions may vary, but in general the behaviour is very similar, if these inclusions are really rutile.

---

<sup>5</sup> Inclusions are foreign substances in a Mineral. These foreign substances might be solid (other minerals) liquid(s) or gasses.

<sup>6</sup> Rutile is a mineral with the chemical Formula  $TiO_2$ .

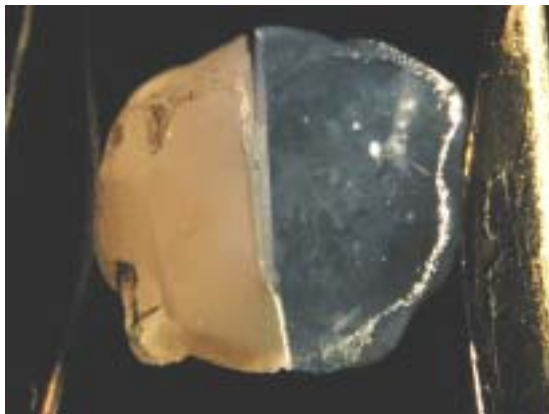

**Figure 20: Photo of a sapphire before and after the treatment. The blue side was heat treated for 15 hours at 1800°C in air to develop the blue colour.**

Another type of positive inclusion is dot-like inclusions as shown in Figure 21.

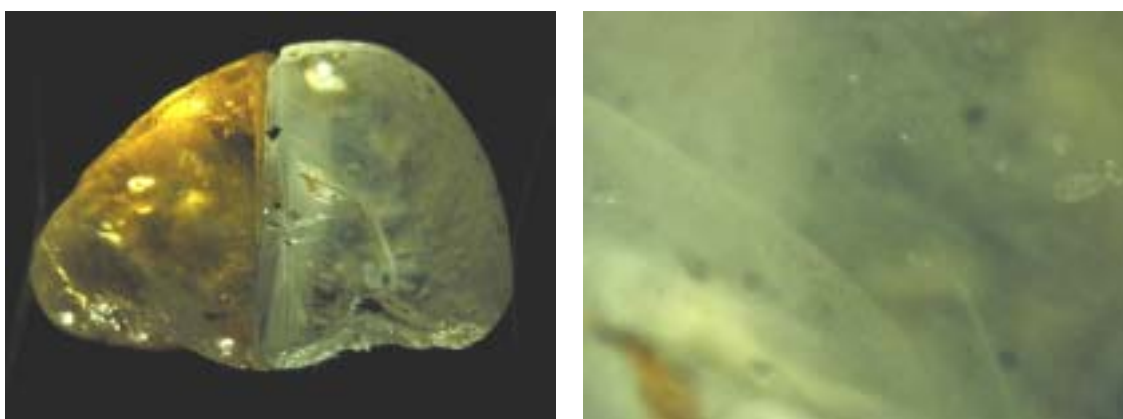

**Figure 21: Left photo showing a sample cut into two parts. The left part of the left photo was heat treated 15 hours in air at 1800°C. The right side of the left photo represent the original untreated state. Right photo showing dot like particles in detail, which are a positive sign for a successful heat treatment.**

These small inclusions are probably small spinels. Parts of these spinels move into the sapphire and stabilise the yellow colour.

The rutile and the small spinels are enemies and thus neutralise each other. In other words if the ratio between them is 1:1, the sapphire will be colourless after the heat treatment. On the other hand the ratio may change often in a stone - this leads to a multi-coloured stone like in Figure 22.

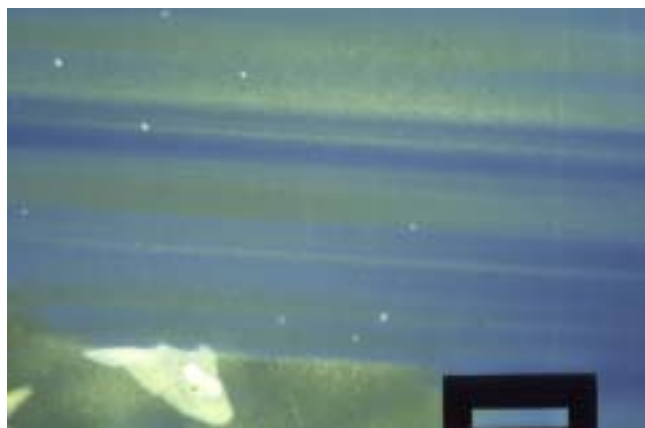

**Figure 22: Multi colour stone with change in the ratio of spinel to rutile inclusions**

Another positive hint is, if there are any blue patches in the stone: The probability, that such a stone intensify its colour is significantly high.

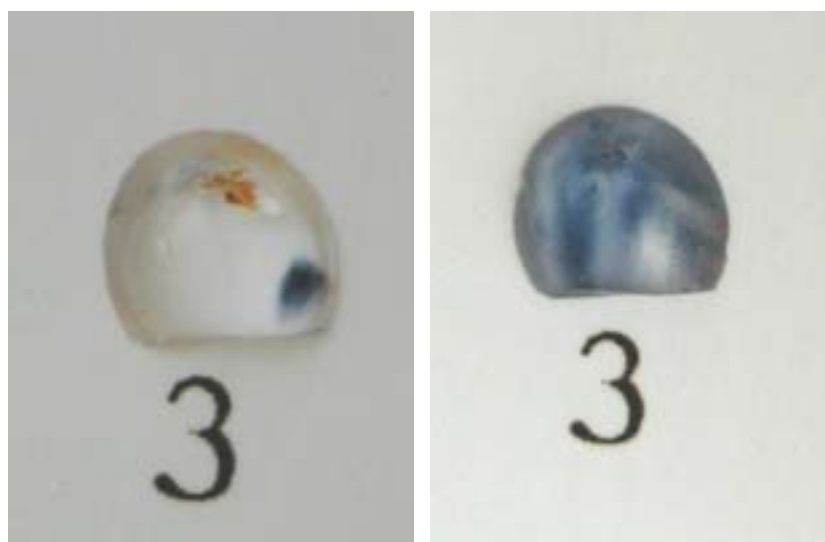
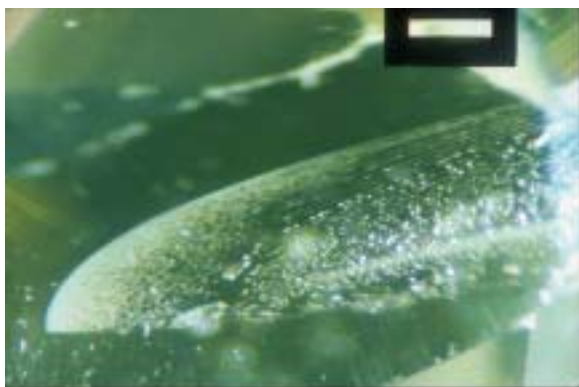

**Figure 23: Blue patch in a stone (Ottu material) before and after the treatment.**

### **Neutral inclusions for the heat treatment of sapphires**

Whether inclusions are neutral or negative depends very often on the treatment temperature. If an inclusion starts to melt, this melting process is combined often with an increase in the volume of the inclusion. Therefore the inclusion needs more room and creates cracks in the stone. A typical tension crack can be seen in Figure 27. A table of the melting points of several important inclusions is shown in Table 2.

It is said in the gemmological literature, that healed cracks are very dangerous for the heat treatment process in Figure 24 a typical healed crack is shown before the heat treatment. In Figure 25 you see the same crack after a high temperature treatment. No changes can be observed, therefore if there are no additional inclusions on these healed cracks, those are **not** dangerous.



**Figure 24: Healed crack before the high temperature treatment**

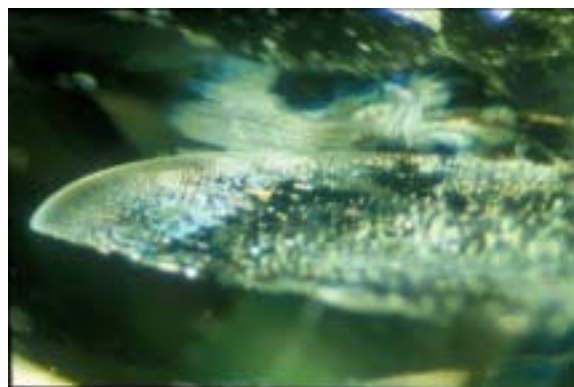

**Figure 25: Same crack as in Figure 24 after the high temperature treatment.**

**Table 2: Melting point and decomposing temperature of some important inclusions**

mineral	melting point
Anatase	see Rutile
Apatite	1660°C**
Brookite	see Rutile
Calcite	decomposition 898°C* with out decomposition 1339°C
Graphite	3652°C*
Hämatite	1594°C*

mineral	melting point
Ilmenite	1450°C**
Ruby/ sapphire	2050°C*
Rutile	1830-1850°C*
Spinel	2135°C*
UO <sub>2</sub>	2878°C*
Uraninite	zu UO <sub>2</sub>
Zircone	2550°C*

\* Source: Handbook of chemistry and physics (1981)

\*\* Source: Themelis (1992)

### **Negative inclusions for the heat treatment of sapphires**

The most dangerous minerals are the minerals which contain water. During the treatment process these minerals will decompose and the water will be extracted from the mineral. Typical minerals that contain water are the micas and Diaspore and Boehmite. Especially the last two are very common in some rubies, although not so common in rubies and sapphires from Sri Lanka. A typical reaction can be observed in Figure 26. After the treatment the stone shows ugly white zones. Therefore experts fill these white areas with borax-based substances again, so ultimately the stone loses these white zones.

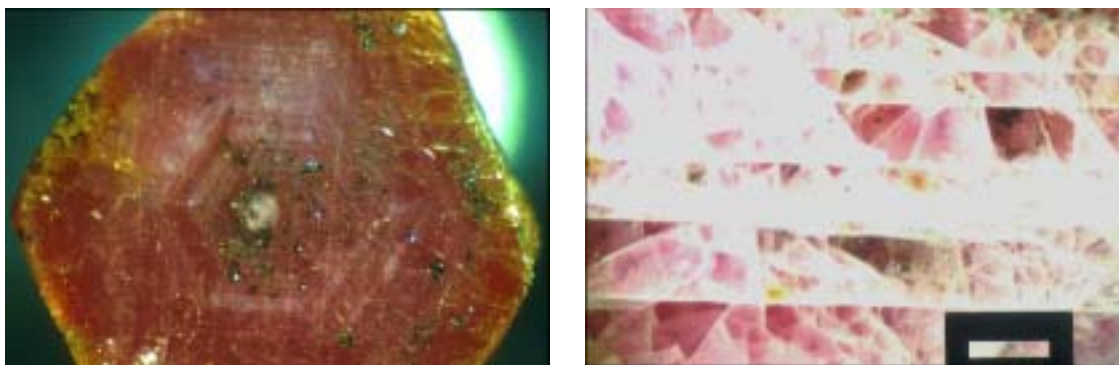
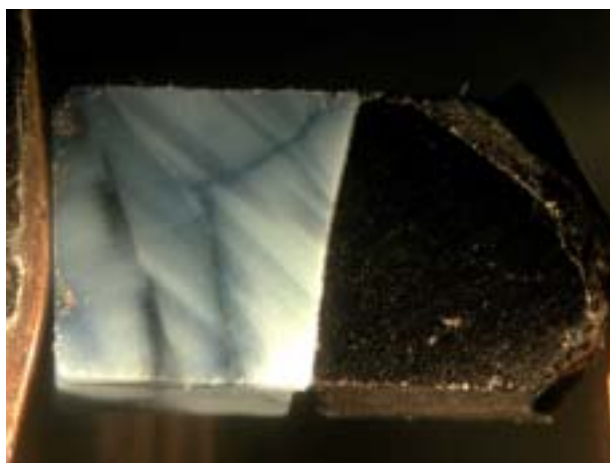

**Figure 26: Ruby before (left side) and after heat treatment (right side). Inclusion lost water and is destroyed therefore.**

As it was pointed out earlier, the melting of an inclusion is one of the most dangerous phenomenon. In Figure 27 you see inclusions in a yellow sapphire before (left side) and after a high temperature treatment (right side). The inclusions produced tension cracks and have been molten. The melt was penetrated into the crack and the typical atoll like inclusion was formed.

**Figure 27: Inclusions in a yellow sapphire before (left side) and after a high temperature treatment (right side).**

If the concentration of a certain positive mineral like rutile is too high, it turns to a negative inclusion (see Figure 28). The left part of the sample was heat treated at high temperatures and the rutile inclusions were now in solution in the sapphire. Simultaneously clarity increased, but the stone turn to a more or less black. This colour is of course also not sellable.



**Figure 28: Sapphire from the north of Madagascar with rutile inclusions before (left side) and after a high temperature treatment (right side).**

Another case where a positive inclusion changes to a negative one is when the inclusions of rutile are too coarse. The rutile inclusions just produce a blue halo and not a homogeneous distribution of colour. Inside the stone you see coarse rutile inclusions before and after a high temperature treatment. In

addition to these halos tension cracks can be observed (see Figure 29 and Figure 30).

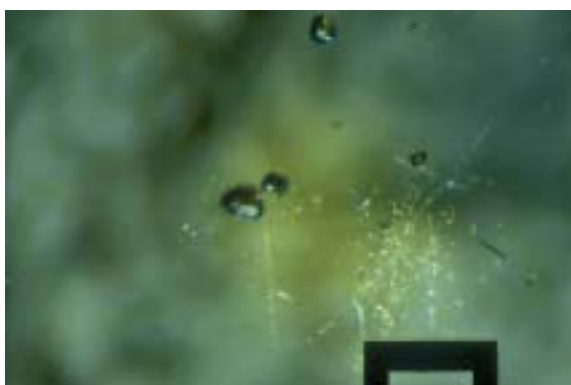

Figure 29: Coarse rutile inclusions before a high temperature treatment

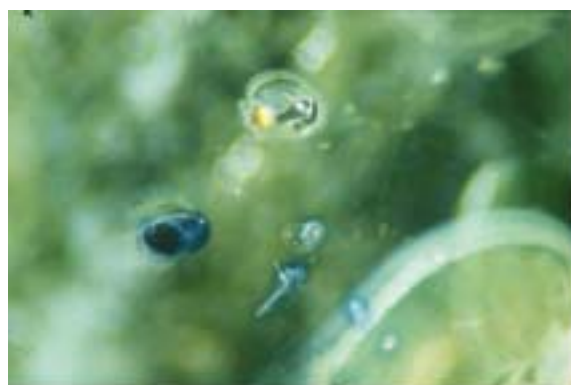

Figure 30: Same inclusions as in Figure 29 after a high temperature treatment

The maximum moving distance of the rutile components into the sapphire is round about 0.009 mm (see Figure 30).

## 4.2 The treatment process for rubies and sapphires

This section will describe only the main principles of heat treating rubies and sapphires. A detailed description is also out of the scope of this chapter.

After the inclusion determination and the inclusion evaluation, the material which seems to be suitable for heat treatment has to be cleaned. This can be done by cutting the foreign material away or by chemical methods. Very often hydrofluoric acid is used to clean the surface in order to remove the inclusions adjacent to the surface. If you use such dangerous acids, please wear always safety goggles and safety gloves. If you do not clean the stone, most of the foreign substances will melt during a high temperature process and the stones will glue together.

After the selection and cleaning process you have to decide whether a **high temperature process** is suitable to dissolve the rutiles (in order to intensify the blue colour) or spinel (to intensify the yellow colour) or whether a **low temperature process** (up to 1300°C) would be sufficient. A low temperature treatment may **reduce the blue hue in sapphires or in rubies** (traditional heat treatment) and so clarity will not be improved.

After you have made this decision the heating process may start. In the case of the high temperature treatment, **if you do not have experience with a certain material**, it is recommended to **do this in stages** (this is called “**Step Tempering**”) at first in oxidising atmospheres<sup>7</sup>.

---

<sup>7</sup> Oxidizing atmospheres means in the case of electrical furnaces in air and in the case of gas furnaces with an excess of oxygen in the oxygen-gas-ratio.

Step tempering means: The first run should be done at 1500°C 1 hour. If the colours of certain samples are alright in colour and clarity take these out of the parcel and heat the rest at 1600°C for 1 hour. Take the samples out of the furnace again and select again the samples which show the perfect colour and clarity. These steps should be done again and again with increasing temperature up to the maximum temperature of the crucible material (in the case of corundum crucibles this temperature is round about 1900°C), or of the furnace.

If even after the highest possible temperature silk<sup>8</sup> in the blue sapphire is observable, these stones have to be heat treated in reducing atmosphere. If it is necessary to exclude yellow zones in a multicoloured stone, those stones also need to be heat treated in reducing atmosphere.

### **4.3 Gemstone enhancement – identification of a heat treatment**

In the seminar several participants have asked how to identify a heat treated stone?

The first proof for a thermal enhancement is, if we recognize atoll like tension cracks as we have seen in Figure 27 and Figure 30. In some cases these tension crack might be observed with a lens, but in most cases you have to use a microscope to identify these tension cracks. A second proof is, if we observe molten surfaces as you can see in Figure 31. This proof you find only in very rare cases, because if the stone is recut proper after a high temperature treatment such molten surfaces are cut away.

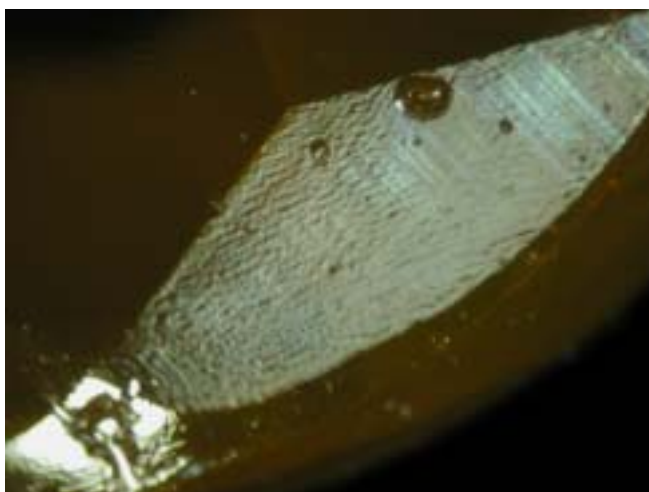

**Figure 31: Molten surface of a heat treated sapphire**

---

<sup>8</sup> Silk describes a small concentration of rutile inclusions in the sapphire.

These two proofs are the most important once, others like how the rutile inclusions look like are not so important

## 4.4 Gemstone Enhancement – Cutting

### Principles of cutting

A detailed description of the cutting process of gemstones is out of the scope of this manual. To allow an assessment of the value of a rough gemstone it is important to understand more about the right desired proportions of the cut gem material.

At first we have to explain some technical terms in the case of faceted gemstones. Let us start with one of the most important cuts which is called the brilliant cut (see Figure 32).

The upper part of the stone is called the **crown** and the lower part is known as the **pavilion**. Between the crown and the pavilion lies the **girdle**. The large facet at the top of the crown is named the **table** and the small facets around the table are called **star facets**. Next to the star facets we recognise the set of **main facets**. Between the main facets and the girdle there are the **upper girdle facets** or **split facets**.

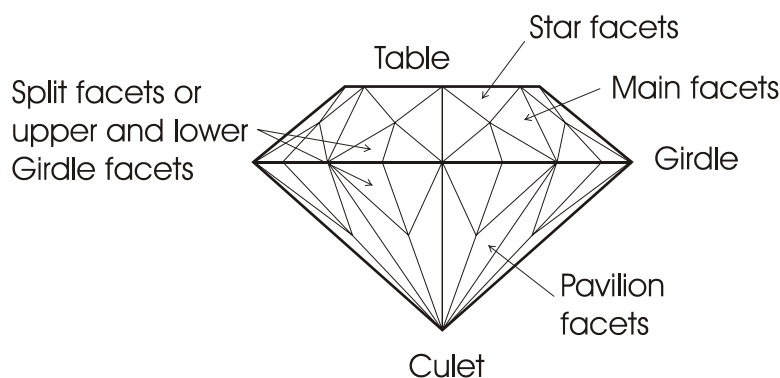
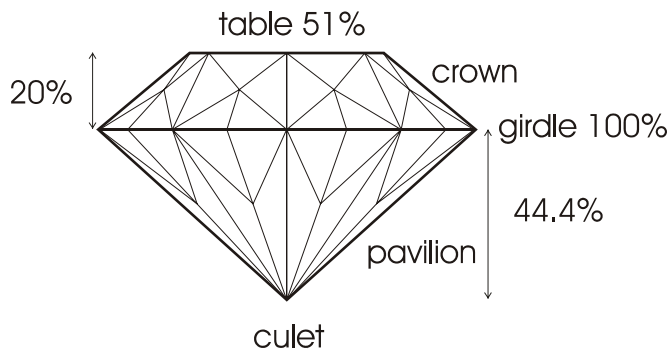

**Figure 32: Brilliant cut and its technical terms**

From the girdle downwards we see the “**lower girdle facets**”. After the lower girdle facets we recognise the “pavilion facets”. The pavilion facets end in a point known as the “**culet**”.

If all these facets have the correct angles to each other and if the size of the table, crown and pavilion has the right proportion the stone will produce the most beautiful sparkling fire.

The exact proportion of a certain gem material depends on its refractive indices and the kind of cut. Let us start with the famous brilliant cut. The total height of the stone should be, in the case of corundum, round about 64% and the table 51% of the diameter of the girdle (see Figure 33).



**Figure 33: Proportion of the brilliant cut for corundum.**

The crown should be around half of the height of the pavilion. And the height from the table to the culet should be round about  $2/3$  (or 67%) of the diameter of the girdle (see Figure 33).

The proportion of the crown to the pavilion should be more or less always the same, but the ratio of the total height of the stone to the girdle diameter may vary from cut to cut from 0.64 (brilliant cut for corundum) to 1.1 (known as the trap or step cut for corundum see Figure 34).

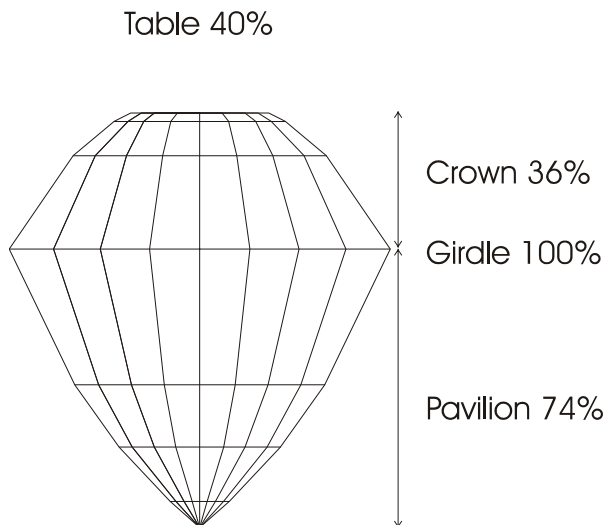

**Figure 34: Proportion of the trap or step cut for corundum**

With these ideal proportions and the right angles the stone will be literally sparkling. This is because most of the light which enters the gem will be reflected internally and will leave the stone at the crown again (see Figure 35).

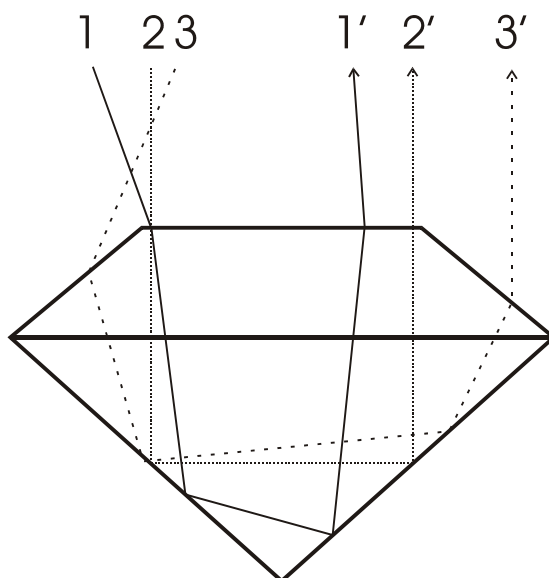

**Figure 35: Paths of light in a brilliant cut corundum.**

If the stone is cut too flat or too deep, most of the light will be lost on its path through the stone. Typical examples of this can be seen in Figure 36.

If the stone is too dark, it is better to cut it a little bit flat and have a nice colour, than to choose the right proportions which might result in a black stone.

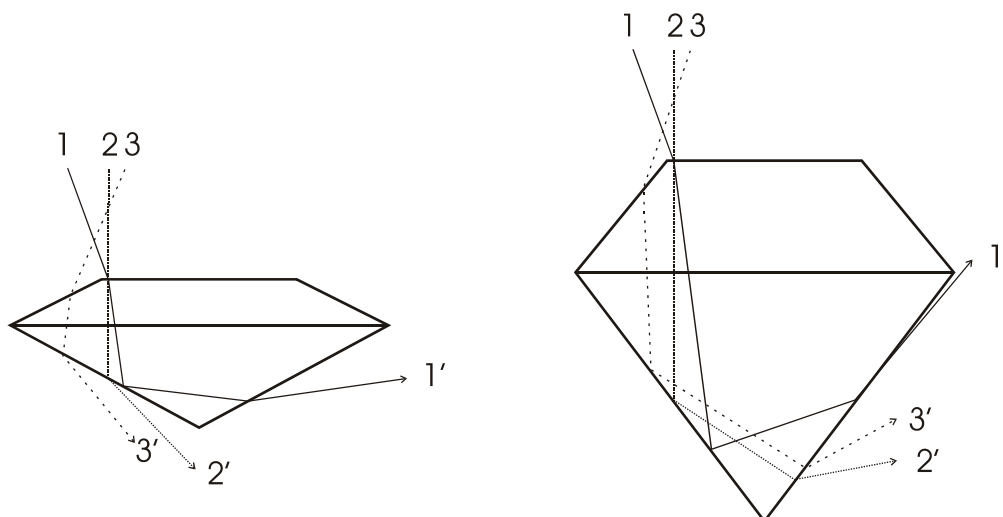

**Figure 36: Paths of light in wrong cut stones.**

**Left is too flat Right is too deep**

**Direction of best colour**

Now we know a little bit about proportion and the exact angles in cutting, but what is the best orientation of the stone? One important criterion is the direction of the best colour.

Only in a few cases is the colour in a mineral the same in every direction. Only cubic minerals like garnet and spinel show the same colour in every direction.

Other gem materials like yellow sapphires show only a small difference in colour in different directions.

Minerals which do not show the same colour in all directions are called **pleochroic** (pleo=multi and chromo=colour). One very typical and famous example of this phenomenon is Cordierite (other names are Iolite, Dichroite and Watersapphire). In Figure 37 you see a cut ball of Iolite. In one direction it has a yellow-brownish colour and in another direction it is an intense blue colour.



**Figure 37: Ball of an Iolite with different colours in two different directions**

In this case it is obvious that the best colour is in the direction of the blue because blue coloured gems fetch a higher price in the market than the yellow colour.

Other well known examples of minerals which are strongly pleochroic are blue sapphire and ruby. In the case of ruby and blue sapphire we know that the best colour is perpendicular to the long direction (see Figure 38). If we want to have the nicest blue we have to cut the table perpendicular to this long direction.

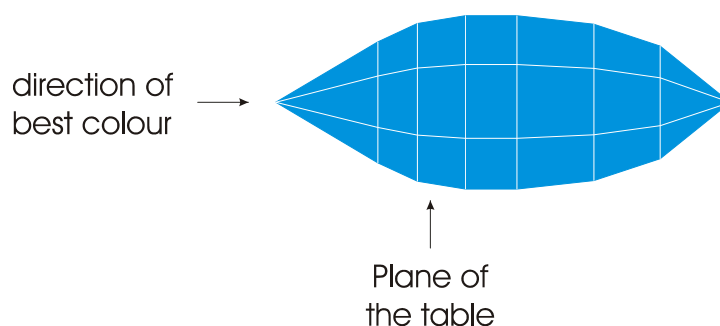

**Figure 38: Typical crystal shape of a sapphire from Sri Lanka. Arrow shows the direction of the best colour and the plane of a possible table.**

In Figure 39 you see a blue sapphire with many inclusions in the centre of the crystal and with some inclusions of the right side. As we know, the table should be perpendicular to the direction of best colour. To get the highest carat value out of the crystal, we therefore have to chose a brilliant cut for the right side of the crystal and a trap cut for the left side. The centre and the very right side portion are useless.

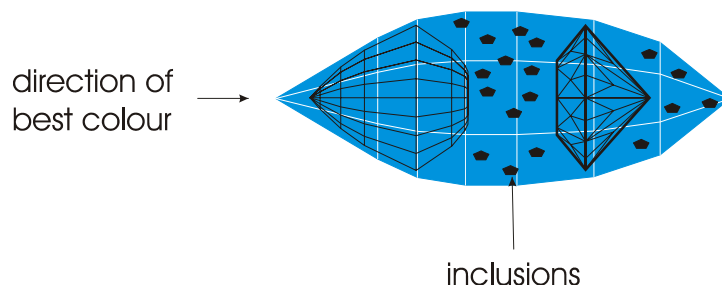

**Figure 39: Blue sapphire with inclusions, showing one possibility how to cut.**

But how can we identify the direction of best colour in the case of Geuda? Geuda stone look only greyish in all directions (see Figure 40). If we have a perfect crystal showing the typical six side (hexagonal) shape, or a crystal fragment, we can determine the direction of best colour by the crystal faces! But what do we do if the rough gem is round and the material does not show any crystal faces?

One possibility to determine the direction of best colour in geuda is to look at the distribution of the greyish inclusions (rutile). In some cases we can observe a six-side distribution of the silk in the gem. If we recognise such a distribution or a part of it (see Figure 40) we are sure, that we look into the direction of best colour.



**Figure 40: Part of a six side zoning in a greyish sapphire (Geuda)**

Another possibility way of identifying the direction of best colour in geuda is to check the rutile inclusions. If the Rutile inclusions are coarse enough, in the direction of best colour we see the strongest gleam (see even star sapphire) (refer to Figure 41).

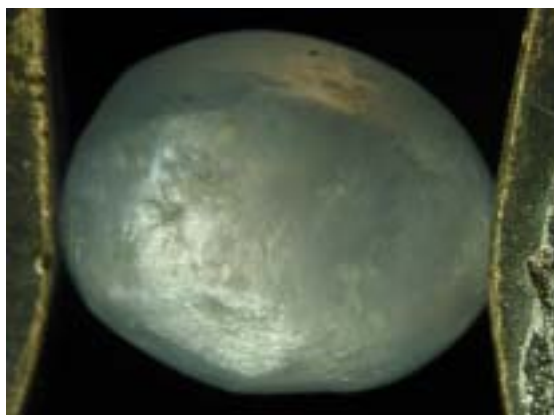

**Figure 41: Gleam of the Rutile inclusions of a sapphire. View is therefore parallel to the direction of best colour.**

### **Inclusions**

If we have a perfect crystal with nice crystal faces, we are able to look directly into the stone through those crystal faces. To see the inclusions a little bit better it is recommended you use a torch with a strong bulb (see Figure 42). Put the torch in one hand and the stone in the other. Press the torch against the stone. Hold the torch perpendicular to the direction of your view and turn the stone in your hand, so that you look from every side into the stone. If the surface of the stone is scratched, you can polish one or two “windows” on it. If this is not possible you can use a liquid with more or less the same refractive index like your stone. In the case of corundum you can use water (better than nothing), Oil (better than water) or methylen iodide (best but expensive).



**Figure 42: Typical gemstone dealer torch. The bulb inside from Maglite.**

### **How to position inclusions in the cut stone?**

In normal cases inclusions are not desired and disturb the impression of a perfect cut gem. A cutter tries to orientate the stone in such a way that the inclusions are cut away. If this is not possible or only possible with an

enormous loss of weight the inclusions should be positioned in such a way that it is in the corner in the case of a trap cut.

In the case of the brilliant cut very small inclusions might be accepted in the area of the star facets and the main facets and small inclusions near the girdle (see Figure 43).

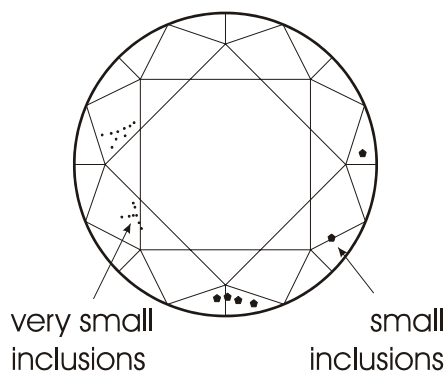

**Figure 43: Position of inclusions in a brilliant cut gem (after Fischer 1996)**

### **Positive inclusions**

As it was pointed out earlier, in most cases inclusions are not desired. However in some cases they are acceptable, if these inclusions produce a special effect, or if these inclusions indicate a positive reaction during a treatment (see chapter 0), they are desired. This is the case for a star (see Figure 44) or cat's-eyes effect. This effect is due to small needle-like inclusions in combination with a cabochon cut.

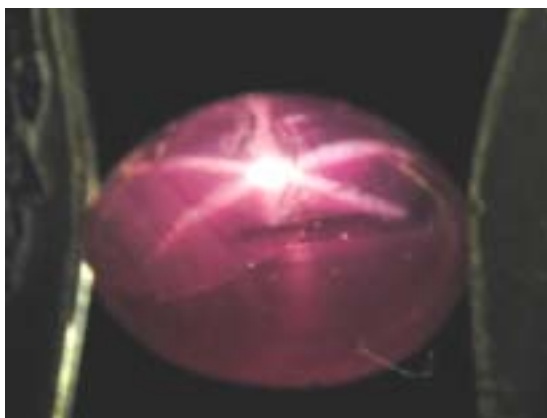
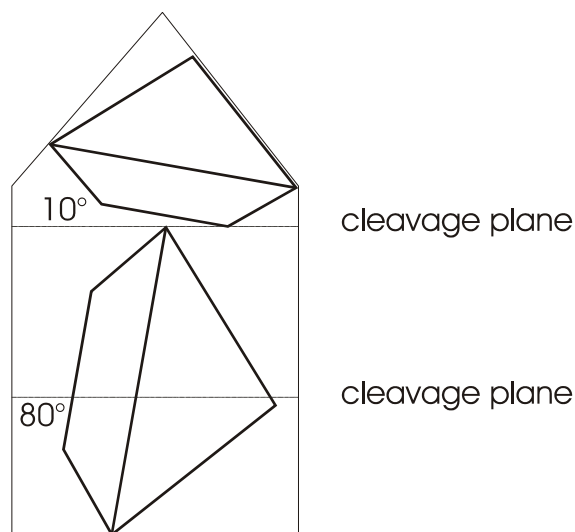

**Figure 44: Star ruby**

The orientation of the star in the case of ruby and sapphire is the same as the direction of best colour.

### Cleavage

If a stone shows cleavage the cutter has to pay particular attention in order to find the right orientation of the table. The table should have an angle of 10 or 80° to the plain of the cleavage (see Figure 45).



**Figure 45: How to oriented the table in a crystal with a cleavage perpendicular to the long direction of the stone (Topaz)**

### Colour zoning

Most gem materials do not show a homogeneous (even) distribution of colour. However even if a rough stone does not possess a homogeneous colour distribution it is possible to give the impression of a homogenous distribution by cutting the stone. This can be done by positioning the intense colour zones into the culet (so-called top colour stone; see Figure 46 a) or more or less parallel to the table (see Figure 46 b).

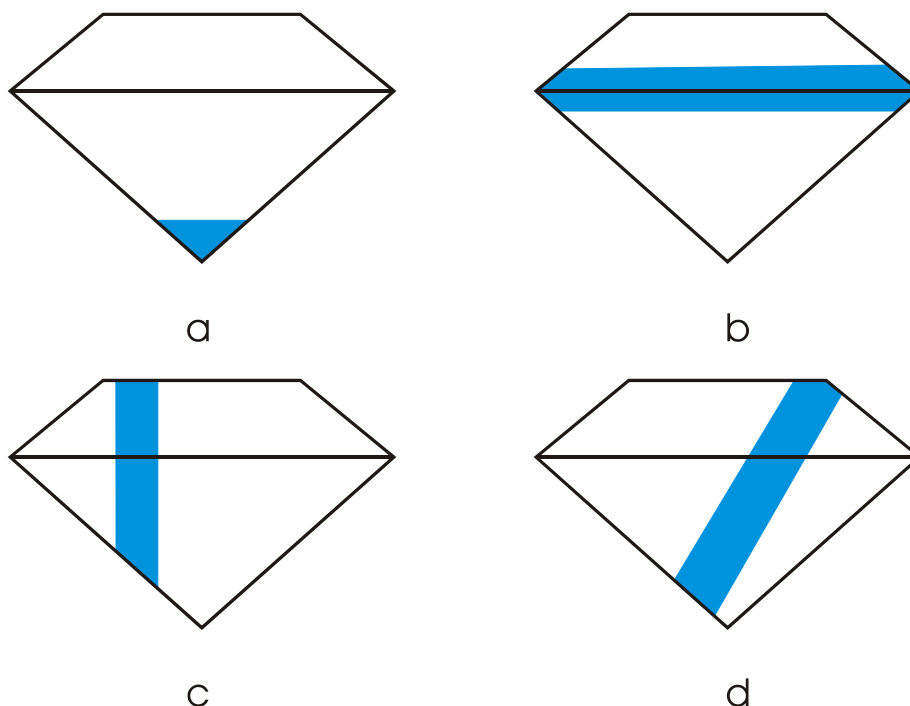

**Figure 46: How to orientate colour zones into a cut stone. a perfect; b perfect; c bad; d better than c.**

In case of barrel shaped crystals of sapphires, colour zoning is often parallel to the direction of best colour. This leads to Figure 46 c where the zoning is strongly visible. In this case it is recommended to make a small deviation to the direction of best colour. This is shown in Figure 46 d.

## **4.5 Calculation of the weight of a cut stone**

Now you know the very basics about gem cutting you should be able to make an estimation of the size of the gem after cutting. With this knowledge you will be able to calculate the weight of the cut stone by using the formulae shown in table 6 (Webster, 1994):

**Table 6: Formulae used to Estimate the Weight of Cut Gems**

<b>Type of Cut</b>	<b>Formula to calculate the Weight of the Gem</b>
Round brilliant	diameter * diameter * depth * specific gravity * 0.0018
Oval faceted	diameter <sup>9</sup> * diameter * depth * specific gravity * 0.0020
Emerald cut	length * width * depth * specific gravity * 0.0026
Rectangular	length * width * depth * specific gravity * 0.0025
Square	length * width * depth * specific gravity * 0.0023
Marquise	length * width * depth * specific gravity * 0.0016
Pear shape	length * width * depth * specific gravity * 0.00175
Cabochons	length * width * depth * specific gravity * 0.0026

With the weight of the cut gem and the quality class of the material which you can expect you are now in a position to be able to estimate the value of your gemstone. Section 5 gives more detail.

Note: Information about the equipment described in chapters 3 and 4, and some possible suppliers, is given in Annex 4

---

<sup>9</sup> Diameter = length + width \* 0.5

## 5 Assessment of a Gem's Value

It is well known, that the value of a certain gemstone depends on the factors we have determined above (carat, cut, colour and clarity) and the demand in the market and the quantity of a certain quality in the market. The last two points vary from day to day. To exclude this uncertainty of the daily business a little bit we have developed the following diagrams. With these figures it is easier to estimate the value of a gemstone. In Figure 47 the weight of sapphires of different qualities is plotted against the value of these qualities in US\$% per carat. To use these Figures you just have to know one daily price of a sapphire of the same colour the quality (clarity) may vary and you can calibrate the whole diagram for all other sizes and qualities. Let us calculate an example.

The daily price of a medium blue sapphire in good quality of 1.706ct is 300US\$. If we look into the Figure 47 the US\$%/carat is 10.344. Now we want to know the price of a medium blue sapphire of 5.117 carat weight of exceptional quality. The value in US\$%/carat is 63,72.

$$\text{carat price} = 63.72\text{US}\$/\text{carat} * 300\text{US}\$/\text{carat} / 10.344\text{US}\$/\text{carat}$$

$$\text{carat price} = 1848,03 \text{ US}\$/\text{carat}$$

The estimated price of the medium blue sapphire of exceptional quality with a weight of 5.117 carat is 1848.03 US\$ /carat.

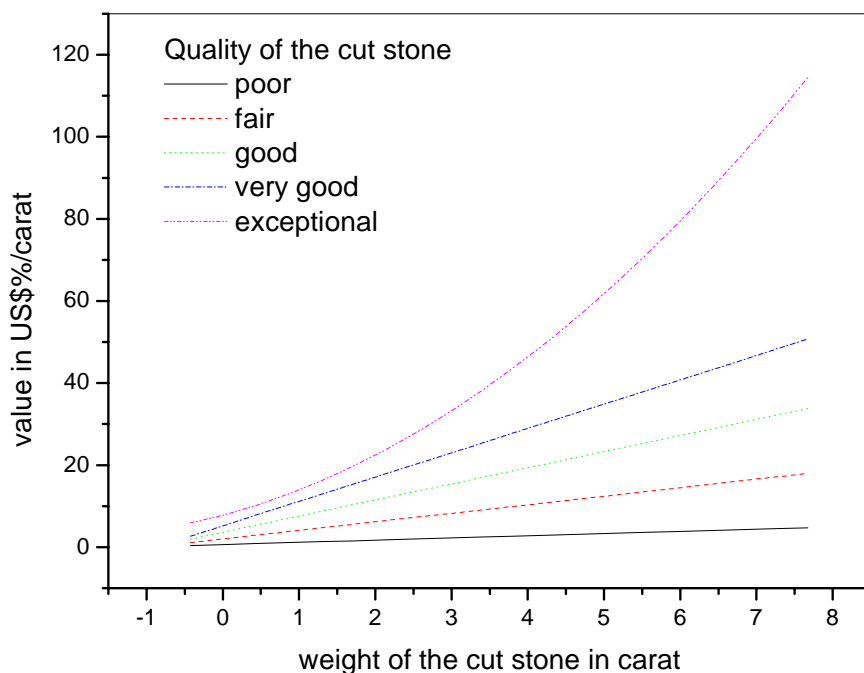

**Figure 47: US\$% plotted against the weight of sapphires of certain qualities. This diagram can be used for yellow, blue and green sapphires and have to be calibrated just by one stone of a certain colour.**

Figure 47 can be used for yellow, blue, green and pink sapphires for Rubies and natural Padparadsha using the diagram in Figure 48 in the same way.

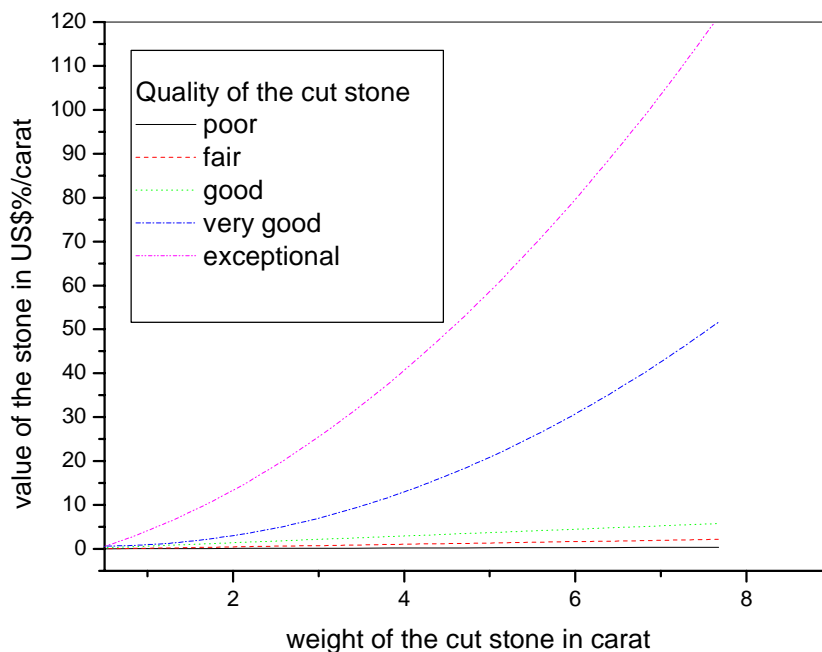

**Figure 48: US\$% plotted against the weight of rubies of certain qualities. This diagram can be used for rubies and Padparadsha and have to be calibrated just by one stone of a certain colour.**

The mentioned prices are indicative only and are subject to changes according to demand and supply. Nevertheless the diagrams may be used as a versatile tool to evaluate corundum gemstones, if they are calibrated with known reference prices each time.

## 6 How to Optimise your Gemstone Sales

The following checklist of points suggests practical ways in which you can make the most of your gemstone mining and sure you sell as much as is possible of the material you find:

### 1. Know your Material:

- Ensure you know the kind of gem material you have
- Classify the expected colour and clarity after treatment and cutting (as described in chapter 4 here)
- Estimate the expected weight of the stone after cutting

### 2. Classify your Customer:

- Are you selling to a gemstone dealer, a mineral collector or a tourist? You are likely to be able to get more money from a tourist but it is important to remain professional and do not try to force them to buy or to cheat them.
- From a gemstone dealer you can profit over a long period of time.
- If the gem material is poor a quality for cabochons but shows a nice crystal shape you may be able to sell this material to mineral collectors.

### 3. Build up “Lots”:

- A lot means a collection of similar gem materials that can be sold collectively as a package. The lots should have more or less the same quality.
- Bigger stones of better quality can be sold as solitaire stones.

### 4. Present the right stones to the right people:

- A customer which deals specifically with sapphire will pay nothing for Spinel.
- Mineral collectors will pay only good prices for minerals with good crystal shape.
- The light in Northern Europe and USA is less intense than the light in Sri Lanka. Therefore Gemstone dealers from the very north may prefer blue sapphires which are a little bit lighter.

### 5. Present your stones in the right conditions:

- The best light is of course daylight.
- Do not sell rubies by fluorescent light. Sell them in incandescent light (light of a bulb). If this is not possible then use daylight.

- Do not sell sapphires in incandescence light (light of a bulb). Sell them in fluorescent light. If this is not possible then use daylight.

**6. Seek competitive selling place:**

- Try to bring your customers together in a situation where competition takes place, for example, organise auctions.
- If you do not have enough material to organise such an auction look for colleagues and organise these auctions together.

## 7 EXPORT AND TRADE

By law the gem export trade has to be monitored by the state through the National Gem and Jewellery Authority. All exports have to be channelled through this body where goods brought for export are checked for quality and genuineness against the respective export invoices. Failure of confirmation results in withdrawal of the export facility. This builds up confidence and a healthy relationship between the buyer and the seller and what is more, this also indirectly promotes the good image of the country.

Sometime ago, the import and export of synthetic and imitation gemstones were not permitted. This was done with a view to promote the sales of indigenous natural material. Now however, in a global context with the expansion and development of the lapidary industry such imports and exports are permitted under correct disclosure of what has been done to them. Synthetic stones can be identified easily using a microscope and you can learn more about this at any basic gem course.

Table 3 shows the annual export of gemstones from 1994 – 1999.

**Table 3: Annual Export of Gemstones 1995 – 2000**

*Quantities (Thousand Carats)*

	1995	1996	1997	1998	1999	2000
<b>Blue sapphire</b>	64.0	39.9	79.5	95.2	155.4	173.7
<b>Star sapphire</b>	435.4	278.0	525.3	92.3	298.4	280.5
<b>Ruby</b>	2.2	1.9	3.0	6.4	11.3	15.8
<b>Star ruby</b>	3.1	71.5	11.5	7.5	11.6	5.4
<b>Cat,s eye</b>	42.6	32.3	61.8	24.0	48.4	48.0
<b>Others</b>	3560.7	4070.1	16469.5	12081.5	12428.9	6126.3
<b>Total Exports</b>	4108.0	4493.7	17180.6	12366.9	12954.0	6649.7

*Values (Rs. Millions)*

	1995	1996	1997	1998	1999	2000
<b>Blue sapphire</b>	432.0	317.1	714.5	1150.7	1600.8	2693.2
<b>Star sapphire</b>	356.5	285.4	597.6	181.6	244.2	285.9
<b>Ruby</b>	30.1	32.0	96.0	55.4	70.7	104.2
<b>Star ruby</b>	42.8	30.7	90.6	33.5	25.0	40.7
<b>Cat,s eye</b>	400.7	311.5	686.4	315.1	384.3	640.3
<b>Others</b>	728.7	522.1	1409.0	1161.6	1256.1	1977.6
<b>Total Exports</b>	1990.8	1498.8	3594.1	2897.9	3581.1	5742.0

*Sri Lanka Mineral Year Book 2001 GSMB (Source : NGJA)*

Table 4 shows local average prices in Sri Lanka for the different gemstone varieties including the non corundum ones.

**Table 4: Approximate average prices of gem varieties found in Sri Lanka (all prices in US\$ per carat for an average quality 1.5 to 2.5 carat weight)**

<b>Gemstone</b>	<b>Approximate Local Price (US \$ per carat)</b>
Alexandrite	1,000
Blue Sapphire	400
Ceylon Ruby (purple, pink, yellow)	400
Yellow Sapphire	200
Chrysoberyl Cat's Eye	100
White Sapphire	60
Star Sapphire	60
Blue Spinel	20
Hessonite	7
Mauve Spinel	6
Rose Garnet (Rhodolite)	6
Brown Tourmaline	5
Amethyst	4
Almandine	3
Citrine	3
Zircon (mixed colours)	3
White Topaz	2

*Source: S.B. Basnayake, Gemmologist, Kandy*

However top quality gems can attain up to about five times these prices (500% more) and poor quality gems can go down by 10% of these prices so these figures serve as a guide only.